

BF2500A 540x1150mm 2500Kg



Premium Pump Unit

Heavy duty 2500kg Capacity low maintenance pump unit with 10 pump stroke to max lift height

Double Rollers and Guide Rollers

Polyurethane Double fork rollers and steer wheels fitted as standard



1000's of Trucks in stock Available in 3 colours



■ **Three position Handle**
(Pump / Neutral / Release)
with Comfort grip handle



Certificate of Conformity

All our trucks are CE / UK CA certified & come with a certificate of conformity

| Model | | | BF2500A |
|--------------------------------------|----|----|--------------|
| capacity | | kg | 2500 |
| pump type | | | BF |
| wheel (drive/load) type | | | Polyurethane |
| size of steering wheel | ΦD | mm | 180*50 |
| size of loading wheel (double wheel) | Φd | mm | 80*70 |
| max. fork height | H | mm | 205 |
| min. fork height | H1 | mm | 85 |
| fork outer width | W | mm | 540 |
| fork length | L | mm | 1150 |
| overall length | N | mm | 1550 |
| overall height | R | mm | 1230 |
| A frame height | T | mm | 460 |
| fork width | S | mm | 160 |
| steel thickness (after painting) | | mm | 3 |
| weight | | kg | 72 |

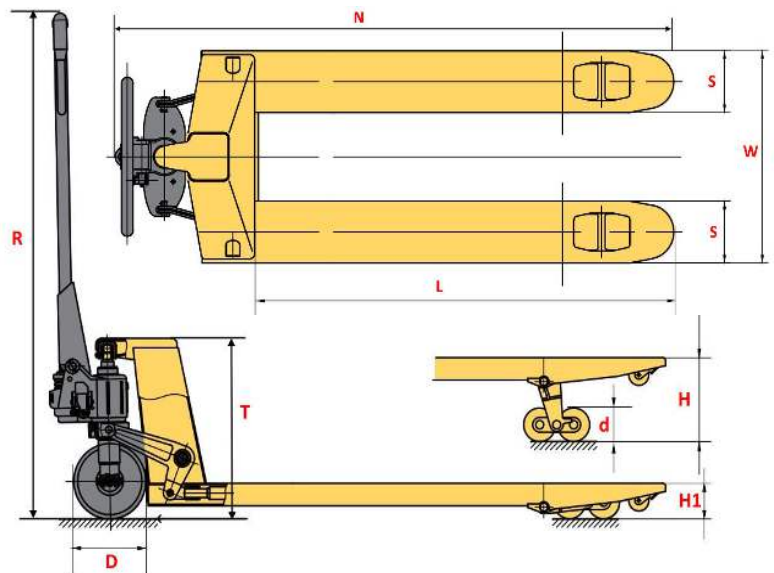

With dimensions over the forks of **540x1150mm**, this is the ideal size for the most common **Euro Pallets of 120x80cm**, but will also lift the common **GKN/Chep pallets of 120x100cm** and many other sizes.

The frames are made from a **heavy grade steel construction** and finished in an **epoxy powder coated paint** that offers greater **Anticorrosion resistance**.



Next Day Delivery
Available



Spare Parts & Technical
Support