

Instruction Manual

SEMI-ELECTRIC HIGH PALLET TRUCK

TRITON EX10



CAPACITY: 1000 KGS

Note: Owner/Operator must read and understand this instruction manual before using the truck.

Specifications

Model	EX10	
Rated capacity	1000kg	
Height of lowered fork	85mm	
Width across fork	540mm	
Fork width	160mm	
Fork length	1150mm/1200	
Front load roller	Ø80x70mm	
Steering wheel	Ø180x50mm	
Lifting time with rated load	19s	
Lifting time without load	11s	
Battery	12V/65Ah	
Weight	158kg	

Precaution

1. Read the manual carefully before operation. Go through every procedure as required in the manual.
2. Lifting the fork to its full range by 1 to 2 times before use to release the air in the hydraulic system.
3. It is prohibited to lift or pull person.
4. It is prohibited to work on the slope or tilt ground.
5. It is strictly prohibited to put your hand or foot under the fork or in the moving parts.
6. Put the load in the center of the fork. Eccentric loading is strictly prohibited.
7. The safety valve in the pump station will be automatically open when it is overloaded. Under such circumstances don't try to lift the load any more by push the "UP" button otherwise that will reduce the life time of the pump station.
8. Switch off the electricity after use.
9. To replace or fill hydraulic oil, the fork should be lowed to its bottom position. The oil to be used should be clean and filtered. The condensation point of the oil should be $\leq - 20^{\circ}\text{C}$, the motion viscosity 20 – 30 cst .

HOW TO ASSEMBLE AND OPERATE

1. Assembly after opening the package

- 1). Take down Screw (33) and Pin(32) accordingly.
- 2). Insert Handle (35) into the handle seat of the Cylinder unit (1900).

Put in Pin (32). Screw in tightly with Screw (33). Put Adjusting Screw(37) (at the lower end of the Chain) into the slot of the Swing Rod (124).

3). Push down the Handle (35), making the Pump Piston (108) downward meantime, to take away Block (60). Thus Handle (35) would be able to return to its upright position. Keep Pulling Handle (49) in the middle position (2). Operate the he Handle (35) up and down freely without any feeling of the blocking.

4). Put the Pulling Handle (49) at the low position (1), operate Handle (35), the fork should be able to lift to its highest position; at the position (3), the fork should be able to lower to its bottom position steadily.

5).Keep Pulling Handle (49) in low position, pump Handle (35) to lift the fork to its highest position. Take away part (212) and cover

(215N). Place Battery (214) into battery tank in the front of Part (70). Connect Connector (241,242) to (+) (-) poles accordingly. Tighten the screws on the Connector. Place part (212) and Cover (215) in. Finally descend fork to its lowest position.

6). Insert Wire and Plug (239) [under Handle (35)] into Socket (239) [under Pump Cover(226)]. Check all electric components such as wire, plug etc. to see if there is any loose, break and short-cut. If everything is normal, switch on the General Switch (236), check the Current Meter(240), the electricity should be over 3 lines.

Below 3 lines (in the red light area), the battery should be charged.

7). Check pipes in hydraulic system, see if there is any leakage or seeping.

8). Place Pulling Handle (49) on Low Position (1), press Up-Button (238) intermittently, the fork should be able to ascend accordingly.

Observe electrical parts and hydraulic system to see any abnormality. If every thing is normal, press Up-Button to lift the fork to its highest position. The Spacing should effect. Then place

Pulling Handle (49) to its highest position (3), the fork should be able to descend smoothly.

9). Repeat the above said procedures for 2 or 3 times to see if there is any abnormality and to drive air away from hydraulic system. The machine is ready for use.`

2. Operation

1). When the machine is ready for use, pull the machine on to a flat solid ground. Push forward and backward. The right and left wheel should swivel flexibly.

2) .Manual ascending:

Place Pulling Handle (49) on Low Position (1), operate Handle (35), the fork should ascend smoothly. Place Pulling Handle (49) on Up Position(37), the fork should descend smoothly to lowest position. Release Pulling Handle (49) onto Mid-position (2), the fork should stop on any position, no descending.

3) .Electric ascending:

Turn on Switch (236). Electricity indicator should be above red line, ie. Green light should be on. Place Pulling Handle (49) on Low Position (1). Press down Ascending Switch (238). The fork should ascend smoothly. Release the Ascending Switch (238), the fork should stop on any position no descend. Place Pulling Handle (49) on Up Position (3), the fork should descending smoothly. Release the Pulling Handle (49) to Mid-position, the fork can stop at any position.

4). This machine is equipped with safety valve to prevent overload. Neither Manual ascending nor Electrical ascending can ascend under overload.

5). After use, turn off Switch (236) to cut off electricity. The electricity meter turns off.

6). When ascending speed remarkably slows down while no green light is on in Electricity Meter (240), The Battery (214) should be recharged. Put the Input Plug on the recharge(218N) into the electricity socket Switch on. The recharging begins automatically. (Red light on). When the electricity is full, the green light in recharge turns on. The indicator in electricity meter shows between 8 – 10 lines. The recharging usually lasts 10 – 12 hours.

Problems、 maintenance and adjustment

1. Trouble shooting

Item	Symptom	Possible cause	Suggested action
1	Fork can not ascend to highest position	Not enough oil	Fill oil (follow the way in No.3, Fig 3)
2	Fork does not ascend while operate the handle	1) Pulling Handle(49) is not in right position 2) Air in hydraulic system	1) Adjust according the way in No.2, Fig 2) 2) To operate the machine up-down to its full range 1-2 times with no load by manual or electrical operation
3	Fork can not descend	1) Pulling Handle(49) is not in right position 2) Fork or other parts are damaged 3) Blocked by foreign object	1) Adjust by following the way in No.2 and Fig 2) Replace damaged parts 3) Take away foreign object
4	Fork does not ascend when press ascending switch	1) Pulling Handle(49) is not in right position 2) Switch is broken 3) Fuse melt down 4) Hydraulic pump does not work 5) Electric-magnetic switch is broken	1) Adjust following the way in No.2 and Fig 2 2) Replace switch 3) Replace fuse. (F ₁ 206, F ₂ 207) 4) Check motor 5) Check electric-magnetic switch
5	Motor does not work	1) Motor is broken 2) Connector and plug-socket are loose 3) Battery is worn out 4) Fuse melt down	1) Check or replace motor 2) Check all connectors 3) Recharge battery 4) Check fuse (F ₁ , F ₂)
6	Electricity in batter is not enough	1) Recharge time is not enough 2) battery is broken	1) continue recharging to 12 – 14 lines 2) Fill in battery liquid or replace battery
7	Seeping oil in piston and pinion	Seals are broken	Replace seals (158)(105)

2. Adjusting position for Pulling Handle(83)

1) Function of three positions:

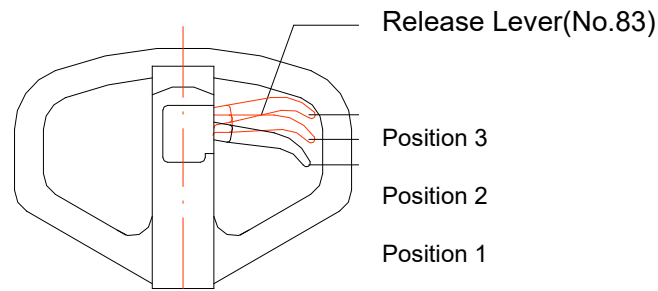

Position 1: ascending the fork

Position 2: neutral

Position 3: descending the fork

2) Adjusting: (Fig 2)

Adjusting Nut (38 78) if Pulling Handle's position is wrong by following the way below:

Position	Adjusting
On Position 3, fork does not descend	Turn Nut upward anticlockwise (+)
On Position 1, fork does not ascend	Turn Nut downward clockwise (-)
On Position 2, not neutral	Adjusting Nut up and down

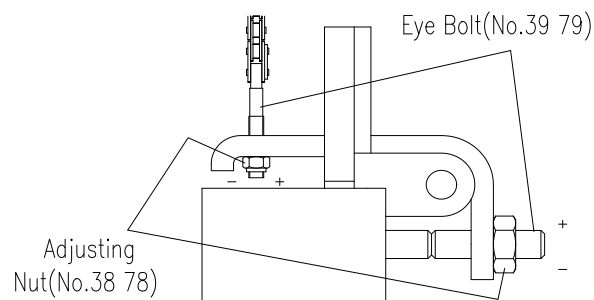

3.Fill oil

Low down the fork to it lowest position. Turn loose Oiling Screw(160). Fill in clean hydraulic oil(see Attention 8 for technical requirement). Then turn Oiling Screw(160) tight. Press ascending Switch(238), check if fork can ascend to its highest position. If not, repeat above procedure. Oil filled should just be enough for fork to ascend to highest position. Don't fill the hydraulic oil up to filling moth once.

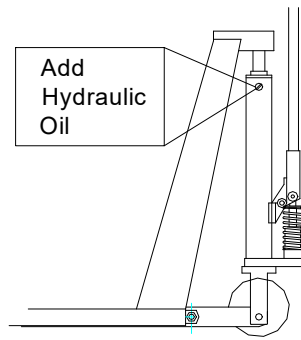

Picture 3

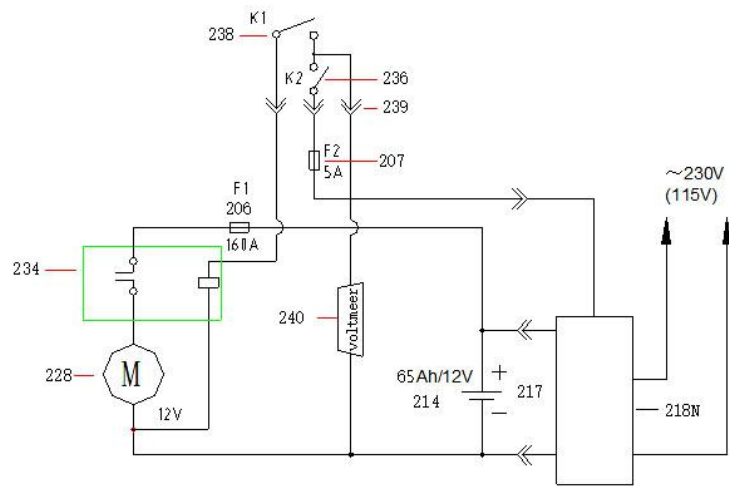

POWER DIAGRAM

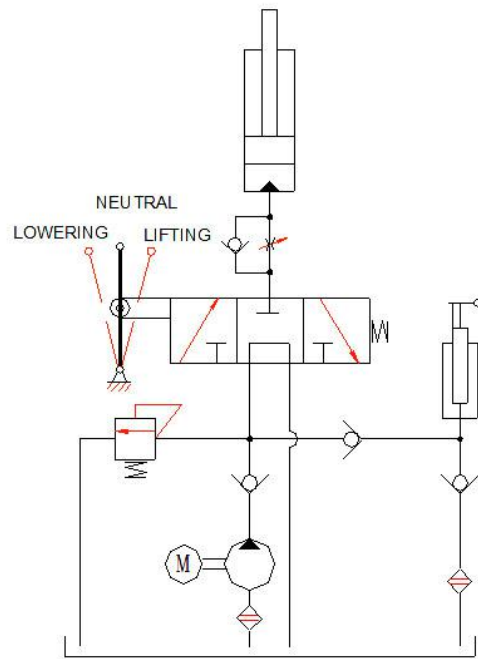
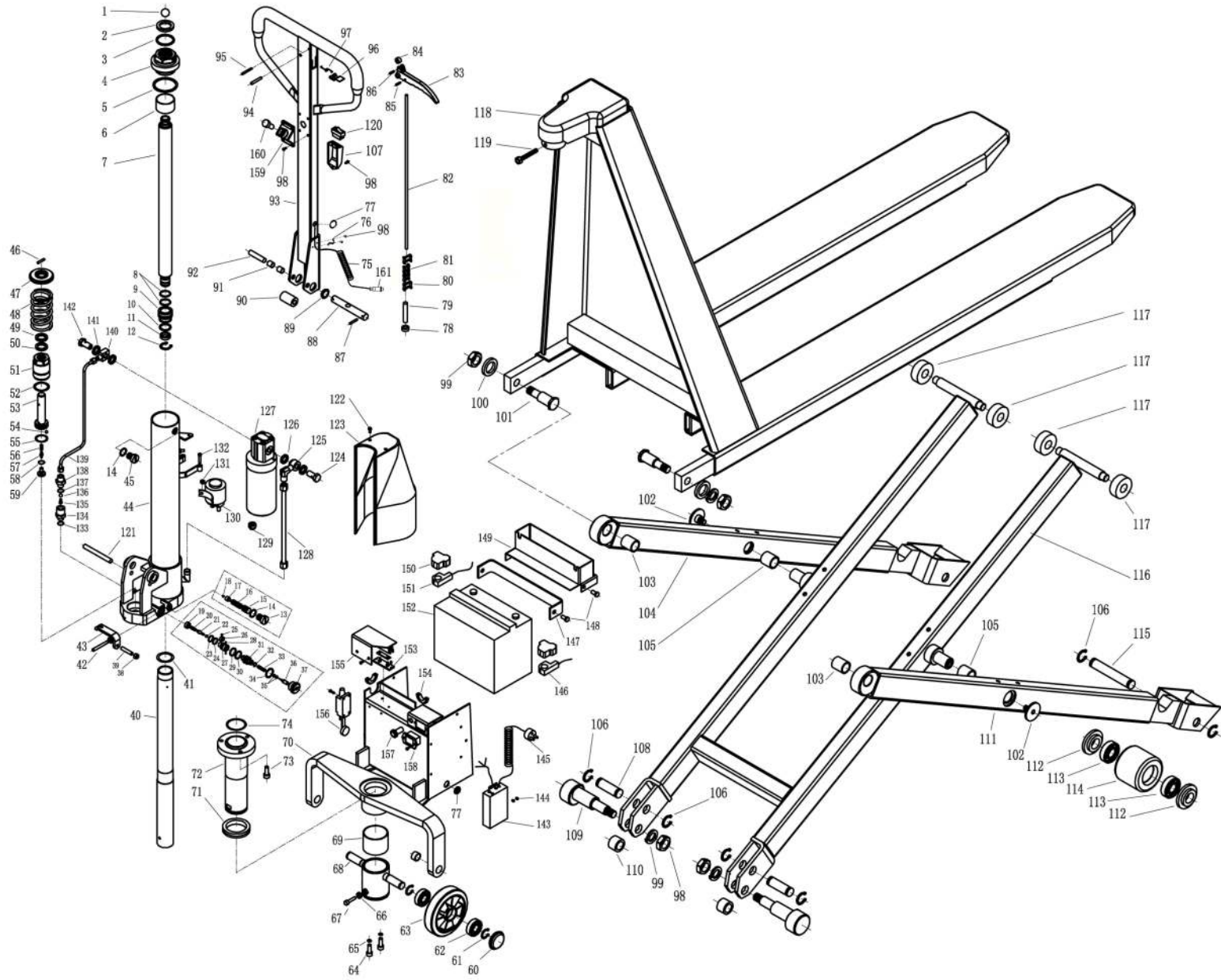

DIAGRAM HYDRAULIC SYSTEM

Parts details



Parts list

NO	Part No.	Description	QTY	NO	Part No.	Description	QTY
1	11020001	Steel ball	1	86	11020086	Spring pin	1
2	11020002	Dust ring 32*40*5/6.5	1	87	11020087	Spring pin	1
3	11020003	O ring 31.5*3.5	1	88	11020088	Shaft	1
4	11020004	Cylinder nut	1	89	11020089	Bushing	1
5	11020005	Seal ring 69*76*2	1	90	11020090	Roller	1
6	11020006	Oil baffle sleeve	1	91	11020091	Bushing	2
7	11020007	Piston rod	1	92	11020092	Pin	1
8	11020008	O ring 15*2.5	2	93	11020093	Handel	1
9	11020009	Piston	9	94	11020094	Spring pin	1
10	11020010	O ring 30*3	1	95	11020095	Spring pin	1
11	11020011	Y ring 25*35*6	1	96	11020096	Plate	1
12	11020012	Snap ring	1	97	11020097	Spring	1
13	11020013	Seal screw	2	98	11020098	Screw M4*8	8
14	11020014	O ring	2	99	11020099	Nut	4
15	11020015	Screw	1	100	11020100	washer	2
16	11020016	Spring	1	101	11020101	Small Eccentric pin	2
17	11020017	Ball seat	1	102	11020102	Axle	2
18	11020018	Steel ball	1	103	11020103	Bushing	2
19	11020019	Cap	1	104	11020104	Left leg	1
20	11020020	Spring	1	105	11020105	Bushing	2
21	11020021	Release Valve	1	106	11020106	Snap ring	8
22	11020022	Steel ball	1	107	11020107	Switch base	1
23	11020023	O ring	1	108	11020108	Shaft	2
24	11020024	Seal ring	1	109	11020109	Eccentric pin	2
25	11020025	Screw	1	110	11020110	Spacer	2
26	11020026	Spring	1	111	11020111	Right leg	1
27	11020027	Valve Insert	1	112	11020112	washer	4
28	11020028	Pin	2	113	11020113	Bearing	4
29	11020029	O ring	1	114	11020114	Load wheel	2
30	11020030	Seal ring	1	115	11020115	Axle	2
31	11020031	Valve Insert	1	116	11020116	Scissor project 540*1150	1
32	11020032	O ring	1		11020116-1	Scissor project 685*1200	1
33	11020033	Spring	1	117	11020117	Roller	4
34	11020034	O ring	1	118	11020118	Frame 540*1150	1
35	11020035	O ring	2		11020118-1	Frame 685*1200	1
36	11020036	Release indicator	1	119	11020119	Screw	1
37	11020037	Valve nut	1	120	11020120	Switch	1
38	11020038	Nut	1	121	11020121	Pin	1
39	11020039	Screw	1	122	11020122	Screw	2
40	11020040	Cylinder	1	123	11020123	Cover	1
41	11020041	O ring	1	124	11020124	Seal screw	1
42	11020042	Spring pin	1	125	11020125	Adjustable screw	1
43	11020043	Rocking beam	1	126	11020126	Washer	3
44	11020044	Pump Housing	1	127	11020127	Hydraulic unit assy.	1
45	11020045	Screw	1	128	11020128	Oil pipe	1
46	11020046	Pin	1	129	11020129	Rubber sleeve	2

47	11020047	Spring cap	1	130	11020130	Relay	1
48	11020048	Spring	1	131	11020131	Nut	2
49	11020049	Dust ring 20*28*4.5/6	1	132	11020132	Screw	2
50	11020050	Y ring 20*28*5	1	133	11020133	Washer	1
51	11020051	Pump	1	134	11020134	Adjustable screw	1
52	11020052	Seal ring	1	135	11020135	Spring	1
53	11020053	Plunger	1	136	11020136	Steel ball	1
54	11020054	Steel ball	1	137	11020137	Washer	1
55	11020055	O ring 30*3	1	138	11020138	Adjustable screw	1
56	11020056	Spring	1	139	11020139	Oil pipe	1
57	11020057	Valve	1	140	11020140	Adjustable screw	1
58	11020058	O ring 7.8*1.9	1	141	11020141	Washer	1
59	11020059	Screw	1	142	11020142	Seal screw	1
60	11020060	Cap	2	143	11020143	Charger	1
61	11020061	Snap ring	4	144	11020144	Screw	16
62	11020062	Bearing	4	145	11020145	Charging line	1
63	11020063	Wheel	2	146	11020146	Battery terminal	1
64	11020064	Screw	2	147	11020147	Plate	1
65	11020065	Spring washer	2	148	11020148	Screw	4
66	11020066	Nut	1	149	11020149	Box	1
67	11020067	Screw	1	150	11020150	Rubber sleeve	2
68	11020068	Wheel yoke	1	151	11020151	Battery terminal	1
69	11020069	Sleeve	1	152	11020152	65Ah battery	1
70	11020070	Frame	1	153	11020153	Fuse	1
71	11020071	Bearing	1	154	11020154	Rubber sleeve	2
72	11020072	Cylinder bush	1	155	11020155	Fuse cover	1
73	11020073	Screw	3	156	11020156	Travel switch	1
74	11020074	O ring	1	157	11020157	Fuse	1
75	11020075	Handle cables	1	158	11020158	Electricity meter	1
76	11020076	Clip	1	159	11020159	Button base	1
77	11020077	rubber sleeve	2	160	11020160	Button	1
78	11020078	Nut	1	161	11020161	Connector	1
79	11020079	Screw	1	13~18	11020162	Safety valve assy.	1
80	11020080	Chain Connector	2	19~37	11020163	Relief valve assy.	1
81	11020081	Chain	1	133~138	11020164	Oil pipe connectors	1set
82	11020082	Release Rod	1	***	11020165	Pump assy.	1set
83	11020083	Release Lever	1	***	11020166	Handle assy.	1set
84	11020084	Roller	1	***	11020167	Seal kits	1
85	11020085	Spring pin	1	***	11020168	Carbon brush assy. for motor	1