

LONG ELECTRIC PALLET TRUCK

MID-EPT15H-550X1800

24 HOURS
BUILT TO WORK



SMART POWERFUL DURABLE

BUILT TO WORK
24
HOURS

SMART SIZE

ALMOST SAME



LIGHT WEIGHT



ONLY 125kgs

80 kgs

EFFICIENCY

3 Times Higher Than Manual Pallet Truck



VS



6%

EASY MAINTENANCE



LIFETIME

3 Times Longer Than Manual Pallet Truck



1 PC

VS

3 PCS

HIGH RETURN OF INVESTMENT

Safety

PRODUCTIVE

1 MONTH COST
RECOVERY

Optimize
your operations
SAVE LABOUR
Brake any time anywhere

Release manpower

Powerful With High Gradeability



Unique brushless technology

Brushless motor, powerful and maintenance free.
Leading in the industry.

 **DC 1.0KW Power**
Brushless motor
Maintenance free

 **Powered traveling**

 **Powered lifting & lowering**

Maintenance free

For brushed motor, carbon brush needs to be replaced every 12 or 18 months.
For EPT models, there is no need to replace the carbon brush.
Maintenance-free, saving maintenance time and cost.

Powerful with high gradeability

To easily move 1.2 ton over the slopes at warehouse entrances.



 — **UNLADEN 4.5km/h**
Traveling speed + **LADEN 4km/h**



Gradeability



PalletTrucks UK .co.uk

Non-stop Working

6s to replace battery

Maintenance-free lithium battery
It takes only 6s to replace battery.
With a spare battery, the unit can keep working 24 hours.

Ensured battery safety

Safe and reliable, no fire, no explosion.
Complying with IEC, UL global standard certification requirements, ensuring the safety of user property.

- Long service life: lithium battery with a long service life.
- High safety performance: it adopts soft package battery technology, built-in protection board and multiple protection to eliminate overcharge and overdischarge.
- Maintenance free: no need to add water.

Compact and durable

Solid build, no breaking

Chassis made by solid materials, no bending, no deformation.
Reinforced rocker arm, push rod, wheel frame and support seat.
No plastic part, less damage.

Most compact unit with same lifting capacity

Suitable for small workplaces such as compact workshops, trucks or vans, tail lifts or elevators.
EPT have the smallest turning radius among similar products.

Integral forks, no splicing

The forks are uniquely designed, easy to handle European pallets, American pallets and plastic pallets.
Solid fork with no deformation, far more durable than other brands of the same category.

Short charging time Charge and use freely

Quick charging: 2 hours to fully charge the battery.

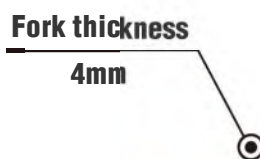

Intelligent Control

When you're moving heavy loads in tight spaces, maneuverability and controllability are critical to ensure safety, productivity and comfort.

The core concept of our products is to make your job easier. With the ergonomically designed handle, the EPT is easy to operate, reduces fatigue and improves work efficiency. Compared to other brands, users prefer to use our EPT series.

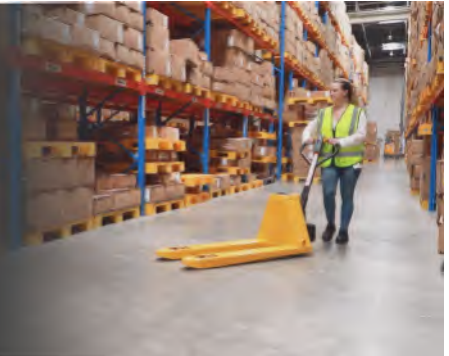

Operator Preferred

Turtle Speed — 01

Horn Remains Pressed & Forward 2 times

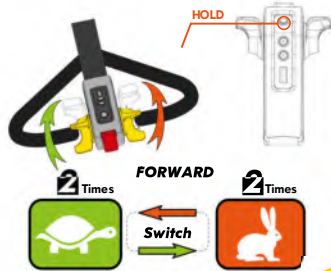

Up-Right Drive — 02

Reverse Button & Forward Throttle Remain Pressed Power On



Engineering Mode (Brake Release) — 03

Horn Remains Pressed Power On

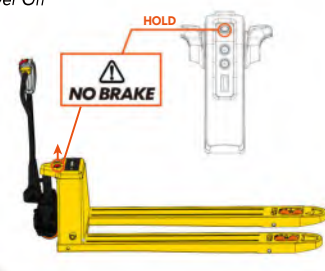

- ⚠ In up-right drive mode, vehicle will move when handle is operated at any position. Please avoid misoperation.
- ⚠ Brake release mode is only for emergencies, not allowed for vehicle with normal conditions.

Comfortable Operation

Easy to operate
Ergonomic handle, comfortable to use.

Leading Technology

CanBus technology is applied on this entry-level electric pallet truck.

Fast And Slow Speed

To match different levels of operator experience, and varied work environments.

Up-right Drive Mode

Convenient to operate in vans, on tail lifts, or inside elevators.

Engineering Mode

When the unit breaks down, it can be moved away manually.



- Recharge alert
- Hour meter
- Powered traveling
- Powered lifting & lowering
- Error code display
- Emergency stop button
- Horn

Slope anti-sliding design

Easy parking on slopes, preventing accidental backing of the machine.

Easy Maintenance

EPT series utilizes integrated diagnostics, error code display and an original service mini-program to facilitate quick problem resolution.

Easy parts replacement

The unique design makes disassembly and assembly simple, reducing machine downtime and operating costs.

- **1 minute**
Replace the drive wheel
- **1 minute**
Replace the handle
- **2 minutes**
Remove the controller
- **3 minutes**
Remove the motor



Error Code Display

Quickly identify the fault during operation.



Specialized service website & mini-program

Users can identify the fault based on the online troubleshooting videos. No limit on time, no limit on location. Easy access to the most professional solution to all possible truck failures.



Professional after-sales support

Specialist guidance is a phone call away.

Ready to Handle Multiple Jobs

With its unique design, EPT series is powerful and maneuverable to meet the application in a wide range of working conditions.

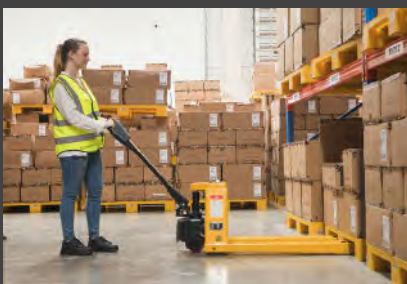

Warehouses/Logistics center



Truck tail lift



Supermarket

Pallet trucks are a necessary investment. Choosing the wrong machine could cause loss in productivity, high cost of machine downtime, unhappy workers, and overall, increased running costs. Choosing EPT series will reward you with long-term value.

EPT Series

- **Powerful**
- **Durable**
- **Easy maintenance**
- **Low use cost**
- **High return on investment**

Basic Configuration

- Horn
- Emergency reverse button
- Forward/reverse butterfly switch
- Lifting / Lowering
- LCD Screen
 - ♦ Battery indicator with hour meter
 - ♦ Error code display
 - ♦ Recharge alert

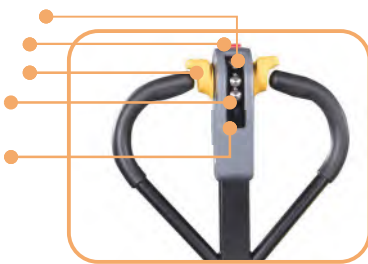

Multi-function Handle
(Full Electric)

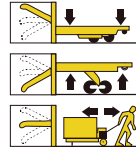

Multi-function Ergonomic Handle
(Semi-electric)



Tandem/Single PU wheel



Lithium Battery



Protection cover
Protect the drive motor,
Anti-foot stamping



Intelligent charger



Electric lifting/lowering



Manual lifting/lowering

Dimensions

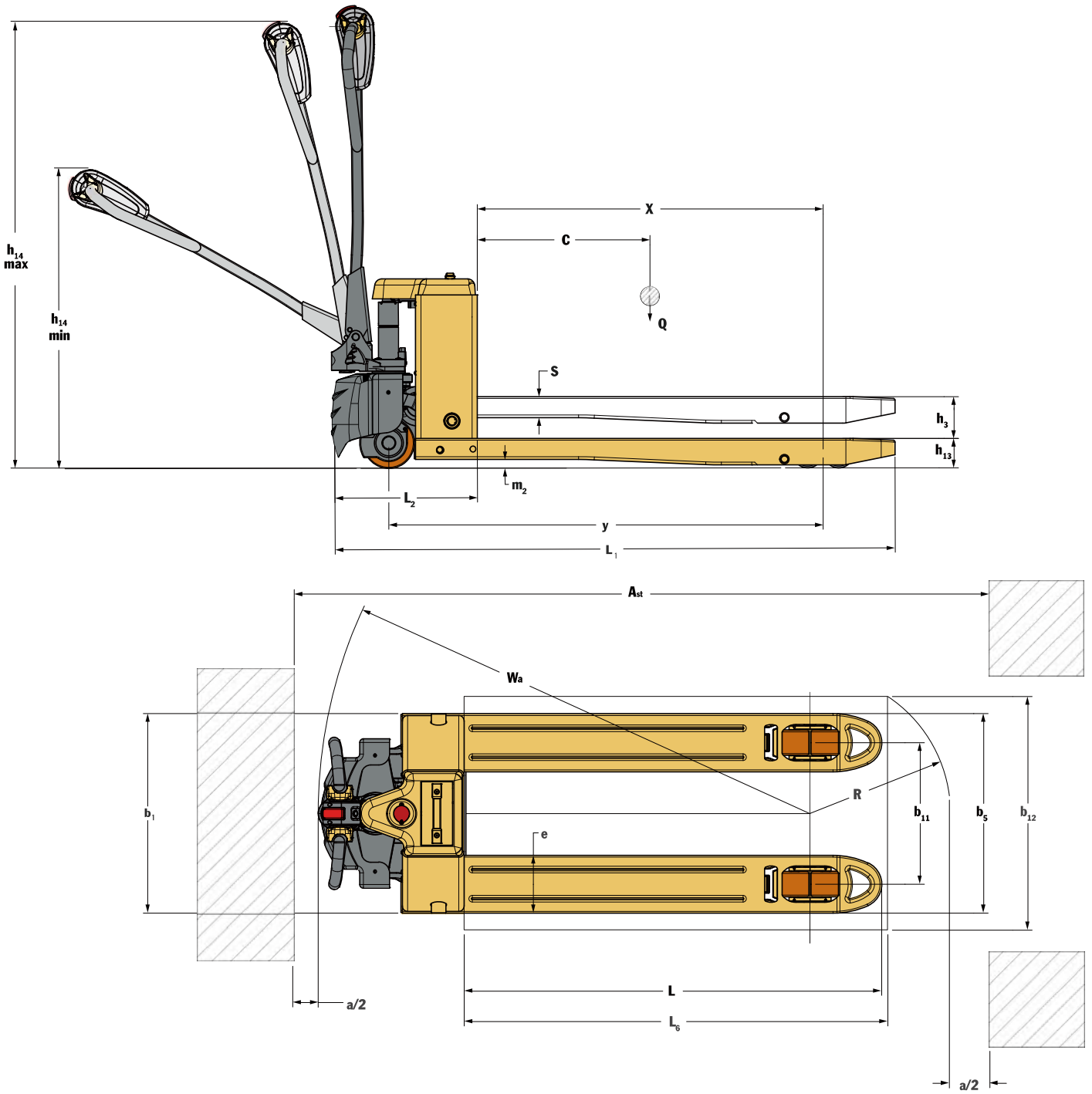

SPECIFICATIONS

MODEL	EPT15H-1800L	
Drive	/	Full-Electric
Operator type	/	Pedestrian
Load capacity/rated load	Q(kg)	1500
Load centre	C(mm)	600
Height, fork lowered	h13(mm)	82 ± 2
Wheelbase	Y(mm)	1847
Wheel	/	PU (Polyurethane)
Wheel size, front	mm	∅140*55
Wheel size, rear	mm	∅80*70(Tandem loading wheel)
Wheels, number front/rear (x = drive wheels)	/	1x+2/4
Lift	h3(mm)	115
Height of tiller in drive position, min./max.	h14(mm)	735/1170
Overall length	l1(mm)	2216
Fork Length	l2(mm)	1800
Overall width	b1(mm)	550
Fork dimensions(Height*width*length)	s/e/l(mm)	58/160/1800
Distance between fork-arms	b5(mm)	550
Ground clearance, centre of wheelbase	h1(mm)	22/137(24/139)
Aisle width for pallets 1000x1200 crossways	Ast(mm)	2899
Aisle width for pallets 800x1200 lengthways	Ast(mm)	2899
Turning radius	Wa(mm)	1995
PERFORMANCE		
Travel speed, laden/unladen	Km/h	4.0/4.5
Lifting speed, laden/unladen	mm/s	18/23
Lowering speed, laden/unladen	mm/s	56/46
Max. gradeability, laden/unladen	%	6%/20%
Drive motor	KW	DC Brushless 1.0 KW
Lift motor	KW	DC 0.8KW
BATTERY		
Battery voltage/nominal capacity	V/Ah	48V/10Ah
Traveling brake	/	Regenerate
Brake	/	Electromagnetic
Sound level at the driver's ear according to EN 12053	dB(A)	<70dB
Service weight including battery	Kg	152/162

| MAKE
YOUR JOB
EASIER!

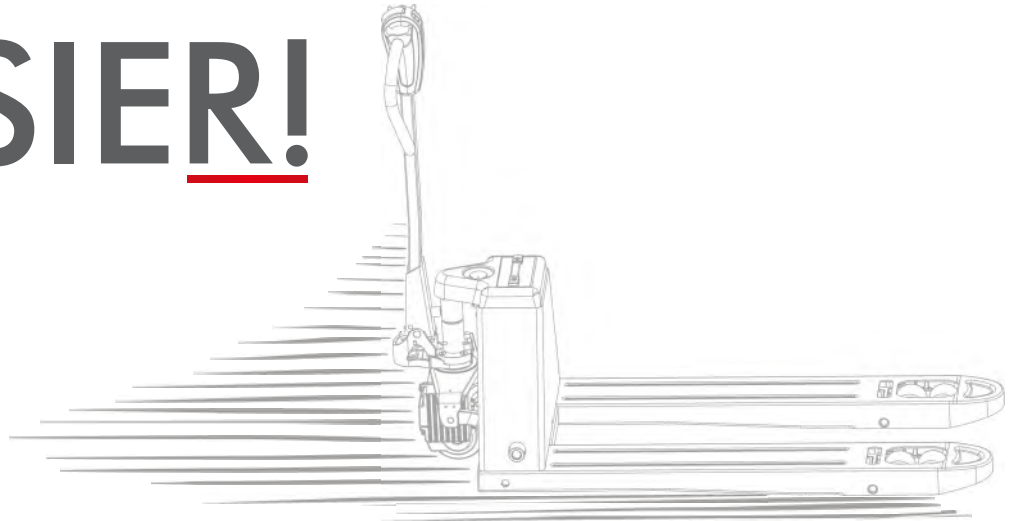

PalletTrucks **UK**.co.uk