

OPERATING MANUAL
PEDESTRIAN ELECTRIC STACKER
TRITON ES15-B-3000

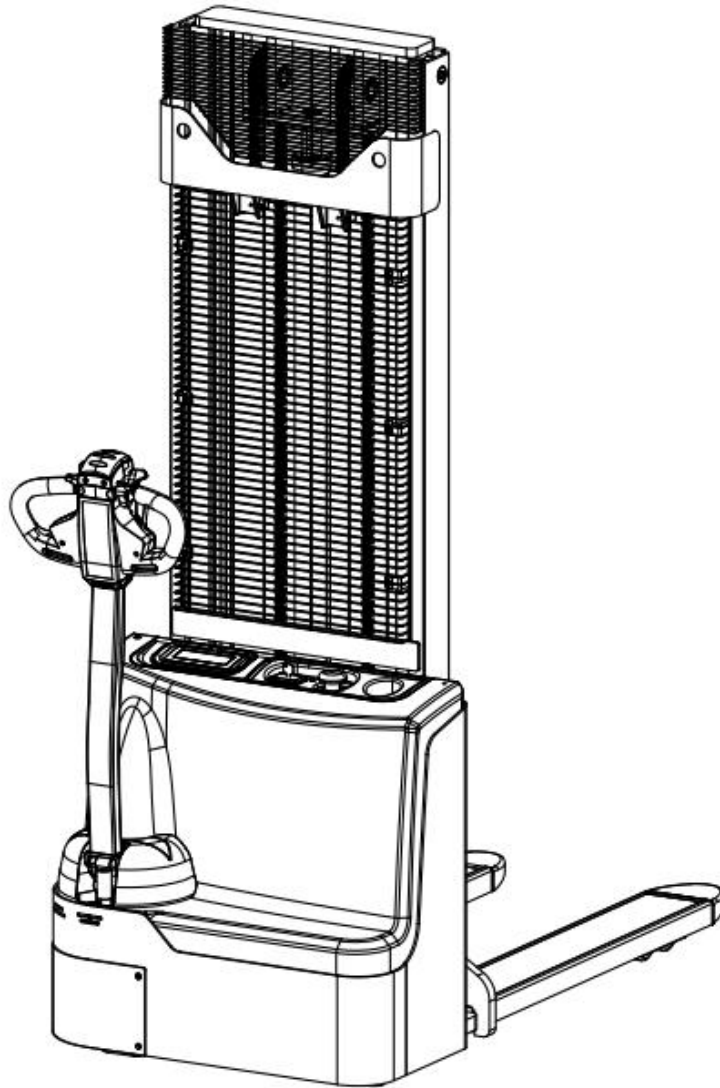

DO NOT REMOVE THIS MANUAL FROM THIS UNIT

Foreword

The OPERATING INSTRUCTIONS are designed to provide sufficient instruction for the safe operation of the industrial stacker. The information is provided clearly and concisely.



Please read and follow all warnings before operation. Please confirm that the safety parts are always intact.

Safety instructions and important explanations are indicated by the following graphics:



Used before safety instructions which must be observed to avoid danger to personnel.



Used before notices which must be observed to avoid material damage.



Used before notices and explanations.



Used to indicate standard equipment.



Used to indicate optional equipment.

The stackers are subject to ongoing development. The manufacturer reserves the right to alter the design, equipment and technical features of the stacker. No guarantee of particular features of the stacker should therefore be inferred from the present operating instructions.

Content

A	Correct use and application	1
B	Introduction	2
1	Application	2
1.1	General	1
1.2	Use according to regulations	1
2	Assemblies	3
2.1	Summary	3
2.2	Main parts	4
3	Standard Version Specifications	5
3.1	Standard technical data	5
3.2	EN norms	7
3.3	Stability & Vibration	7
3.4	Static testing coefficient for enhancing attachments	7
4	Identification points and data plates	7
4.1	Data plate	8
4.2	Capacity	8
C	Transport and Commissioning	9
1	Lifting by crane	9
2	Securing during transport	9
3	Using for the first time	10
4	Running-in of new stacker	10
D	Battery Maintenance, Charging & Replacement	10
1	Attention for using battery	11
2	Battery maintenance	11
2.1	Maintenance frequency	11
2.2	Battery Storage	12
2.3	Battery Maintenance, Fault and solutions	12
3	Charging the battery	13
3.1	Charging Cautions	13
3.2	Power interface	14
3.3	Battery charging	14
4	Battery changed and installation	15
4.1	Battery changed steps	15
5	Battery charge / discharge indicator	16
E	Operation	16
1	Safety Regulations for the Operation	16
2	Display and control	17
2.1	Display	18
2.2	Handle control box	18
2.3	Control	19
2.4	Optional configuration-intelligent control	20
2.5	The tiller handle display	21
2.6	Handle self-diagnostic function	22
2.7	Fault and troubleshooting	23
3	Operating	24
3.1	Check before operation	24

3.2	Starting up	25
3.3	Using	26
3.3.1	Safety regulations for operation	26
3.3.2	Travelling, Steering, Braking	26
3.3.3	Collecting and depositing loads	28
3.4	Parking.....	28
3.5	Deposit the stacker	29
3.5.1	Deposit the stacker for long time	29
3.5.2	Start running after deposit for a long time	29
F	Maintenance.....	29
1	Operational safety and environmental protection	29
2	Maintenance Safety Regulations	29
3	Servicing and inspection	30
4	Scheduled maintenance tables	31
5	Maintenance checklist	31
6	Oil and lubrication	34
6.1	Replace hydraulic oil	34
6.2	Replace the key safe parts periodically	36
G	Structure, Principle and Maintenance.....	36
1	Driving system	36
1.1	Drive unit structure	36
1.2	Working principle	37
1.3	Notice to installment and use	37
1.4	Fault and troubleshooting	38
1.5	Drive motor	38
1.6	Electromagnetic brake	41
1.6.1	Working principle	41
1.6.2	Brake installment	42
1.6.3	Maintenance	43
1.6.4	Brake air gap adjustment	43
1.6.5	Braking principle diagram	44
1.6.6	Common fault and troubleshooting	45
2	Hydraulic system	46
2.1	Hydraulic system working principle.....	46
2.2	Hydraulic Schematic Diagram	47
2.3	Hydraulic unit	48
2.4	Hydraulic system fault diagnosis and correction	49
3	Electric system	49
3.1	Electrical Schematic diagram	50
3.2	Drive controller	51
3.2.1	Controller port and function	51
3.2.2	Maintenance	51
3.2.3	Handheld programmer	52
3.2.4	Fault Code Table for handle control box	52
	Attachment: List of Bolt Tightening Torques	54

A Correct use and application



The “Guidelines for the Correct Use and Application of Industrial stackers” are supplied with the stacker. The guidelines are an integral part of the operating instructions and must be observed. National regulations apply in full.

The stacker described in the present operator manual is an industrial stacker designed for lifting and transporting load units. It must be used, operated and serviced in accordance with the present instructions.

Any other type of use is beyond the scope of application and can result in damage to personnel, the stacker or property. In particular, avoid overloading the stacker with loads which are too heavy or placed on one side. The data plate attached to the stacker or the load diagram are binding for the maximum load capacity. The industrial stacker must not be used in fire or explosion endangered areas, or areas threatened by corrosion or excessive dust.

Proprietor responsibilities: For the purposes of the present operator manual the “proprietor” is defined as any natural or legal person who either uses the industrial stacker himself, or on whose behalf it is used. In special cases (e.g. leasing or renting) the proprietor is considered the person who, in accordance with existing contractual agreements between the owner and user of the industrial stacker, is charged with operational duties.

The proprietor must ensure that the stacker is used only for the purpose it is intended for and that danger to life and limb of the user and third parties are excluded.

Furthermore, accident prevention regulations, safety regulations and operating, servicing and repair guidelines must be followed. The proprietor must ensure that all stacker users have read and understood this operator manual.



Failure to comply with the operator manual shall invalidate the warranty. The same applies if improper work is carried out on the stacker by the customer or third parties without the permission of the manufacturer’s customer service department.

Attaching accessories: The mounting or installation of additional equipment which affects or supplements the performance of the industrial stacker requires the written permission of the manufacturer. In some cases, local authority approval shall be required.

Approval of the local authorities however does not constitute the manufacturer’s approval.

B Introduction

1 Application

1.1 General

This manual only applies to electric stackers, it is designed for use on level floors to lift and transport palletized goods. Open bottom pallets or roll cages can be lifted.

The capacity can be obtained from the data plate.

The capacity with respect to lifting height and load centre of gravity is indicated on the capacity plate.

1.2 Use according to regulations

- Pick up and place goods with open bottom pallets.
- Transport goods with pallets.
- Can only be used on roads with good visibility and permission from the device user;
- When there is insufficient lighting in the workplace, please increase lighting;
- Used within the specified rated load;
- The maximum climbing slope during full load driving is 6%;
- When carrying goods uphill, keep the goods in front; When carrying goods downhill, keep people in front. When driving uphill, it is prohibited to drive horizontally or diagonally.



For stacker operation, the following normal climatic conditions apply:

- | | |
|--|----------|
| - Average ambient temperature for continuous duty: | +25°C |
| - Maximum ambient temperature, short term (up to 1h): | +40°C |
| - Lowest ambient temperature for stackers intended for use in normal indoor conditions: | +5°C |
| - Lowest ambient temperature for stackers intended for use in normal outdoor conditions: | 0°C |
| - Altitude: | ≤2000m |
| - Operating lighting: | ≧ 50 Lux |



WARNING

- Prohibit the use of this device within the explosion-proof zone.
- Prohibit carrying people.
- Prohibit overloading.
- Prohibit pushing and pulling goods.
- Prohibit multiple pallet stackers from collaborating on the same goods.
- It is prohibited to use this equipment on uneven, potty and loose road surfaces.
- It is prohibited to use this equipment in places with water on the road surface and humid environments exceeding 75%.

2 Assemblies

2.1 Summary

This operation manual introduces the electric stacker, which is suitable for use in places with low work intensity.

Users can obtain related information such as rated load from the product model.

WS15H-B	Model No.
WS	Economic full-electric stacker
15	Max. Capacity,15=1500kg
H-B	Product series number

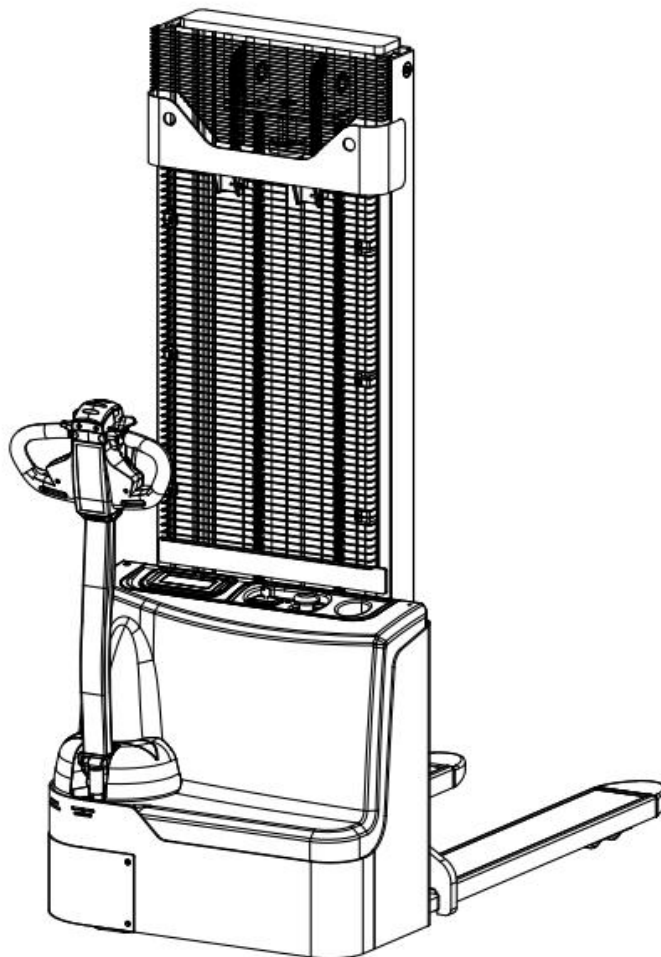

2.2 Main parts

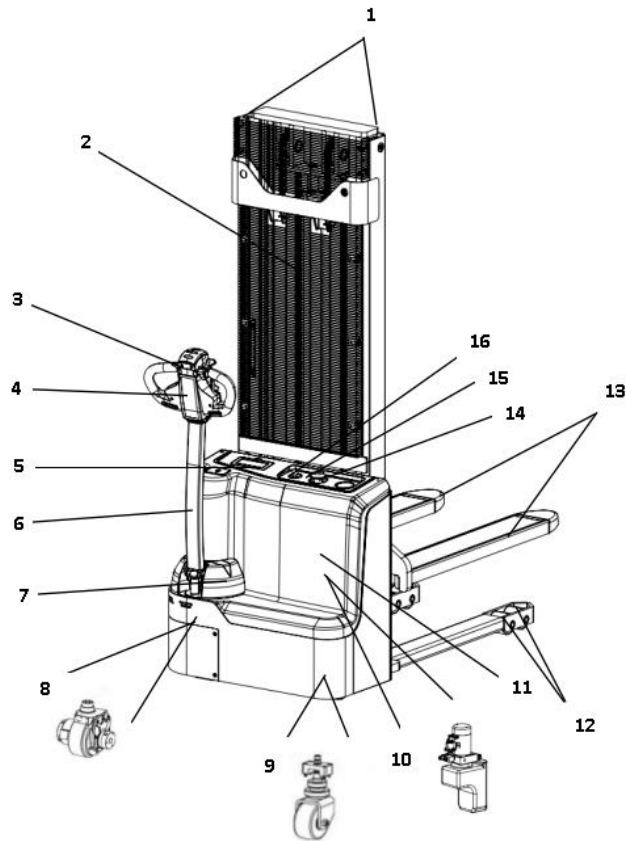

Item No.	Type	Parts name
1	○	Mast
2	○	Cylinder assy.
3	●	Accelerator assy.
4	●	Handle control box
5	○	Charging plug
6	●	Handle tube
7	●	Bottom cover
8	●	Drive unit assy.
9	●	Universal wheel assy.
10	●	Hydraulic unit assy.
11	●	Upper cover
12	●	Load wheel
13	○	Fork
14	●	Emergency stop switch
15	●	Charging LED
16	●	Key switch with keys
	■	Intelligent control keys

● = Standard ■ = Optional ○ = Different specifications available for selection

3 Standard Version Specifications



The technical data provided below are all standard data. The manufacturer reserves the right to make technical changes and supplements.

3.1.1 Standard technical data

Distinguishing marks	1.2	Model			WS15H-B					
	1.3	Drive	—	—	Battery					
	1.4	Operator type	—	—	Pedestrians					
	1.5	Load capacity/rated load	Q	kg	1500					
	1.6	Load centre distance	c	mm	600					
	1.8	Load distance, centre of drive axle to fork	x	mm	796					
	1.9	Wheelbase	y	mm	1210					
Weight	2.1	Service weight (without battery)	—	kg	492.4	512.4	539.4	548.4	558.4	595.4
		Service weight (With 71Ahbattery) @2.5mlifting height	—	kg	539	559	586	595	605	642
		Service weight (With 89Ahbattery) @2.5mlifting height	—	kg	544	564	591	600	610	647
	2.2	Axle loading, laden front/rear	—	kg	626/1461					
2.3	Axle loading, unladen front/rear	—	kg	440/147						
Tyres/ chassis	3.1	Wheels	—	—	PU					
	3.2	Wheel size, front	∅ x width	mm	∅210x70					
	3.3	Wheel size, rear	∅ x width	mm	∅80X70					
	3.4	Additional wheels (dimensions)	∅ x width	mm	∅115X55					
	3.5	Wheels, number front/rear (x = driven wheels)	—	—	1x + 1 / 4					
	3.6	Tread, front	b10	mm	550					
	3.7	Tread, rear	b11	mm	390(560 fork width)/525(680 fork width)					
Dimensions	4.2	Lowered mast height	h1	mm	1480	1730	1980	2130	2230	2550
	4.4	Lift height	h3	mm	2000	2500	3000	3300	3500	4000
	4.5	Extended mast height	h4	mm	2435	2935	3435	3735	3935	4370
	4.9	Height of tiller in driving position, min./max.	h14	mm	910/1270					
	4.15	Height, lowered	h13	mm	85±2					
	4.19	Overall length	l1	mm	1730(1150 fork length)/1800(1220 fork length)					
	4.20	Length to face of forks	l2	mm	580					
	4.21	Overall width across chassis	b1	mm	820					
	4.22	Fork dimensions	s/e/l	mm	70X160X1150/1220					
	4.25	Width over forks	b5	b5(mm)	560/680					
	4.32	Ground clearance, centre of wheelbase	m2	m2(mm)	30					
	4.34.1	Aisle width for pallets 1000 × 1200 crossways	Ast	Ast(mm)	2268					
	4.34.2	Aisle width for pallets 800 × 1200 lengthways	Ast	Ast(mm)	2194					
4.35	Turning radius	Wa	Wa(mm)	1425						
Performance data	5.1	Travel speed, with/without load	—	km/h	4/4.5					
	5.2	Lift speed, without load/with load	—	mm/s	115/72					
	5.3	Lowering speed, without load/with load	—	mm/s	133/116					
	5.8	Max. gradeability, with/without load	—	%	5/10					
	5.10	Service brake	—		Electromagnetic					
Electric-engine	6.1	Drive motor rating S2 60 min	—	kW	0.75					
	6.2	Lift motor rating at S3 15%	—	kW	2.2					
	6.4	Battery voltage/nominal capacity K5	—	V/Ah	●12/71x2 ■12/89 x 2					
	6.5	Battery weight +/- 5%	—	kg	●23.2 x 2(71Ah) ■25.8 x 2(89Ah)					
	6.6	Energy consumption according to EN 16796	—	kWh	0.45					
	Addition Data	8.1	Type of drive control	—		DC speed control				
8.4		Sound level at the driver's ear according to EN 12053	—	dB(A)	<75					

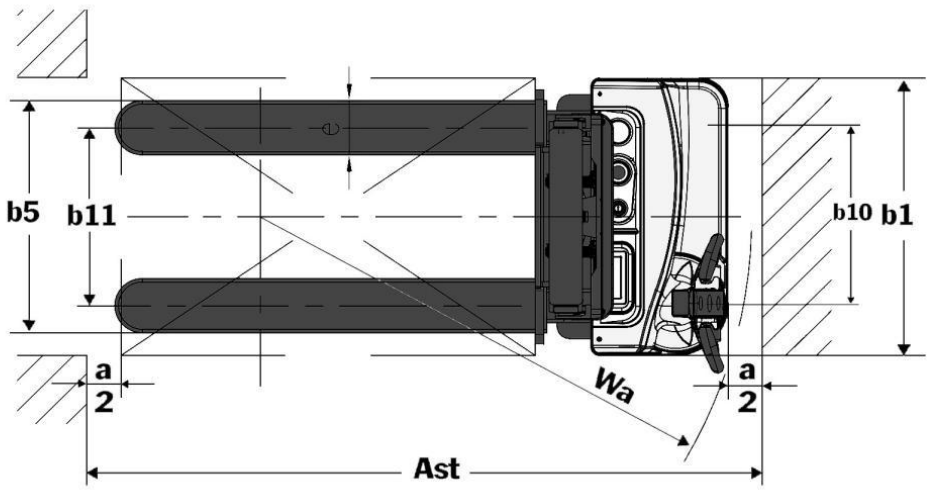
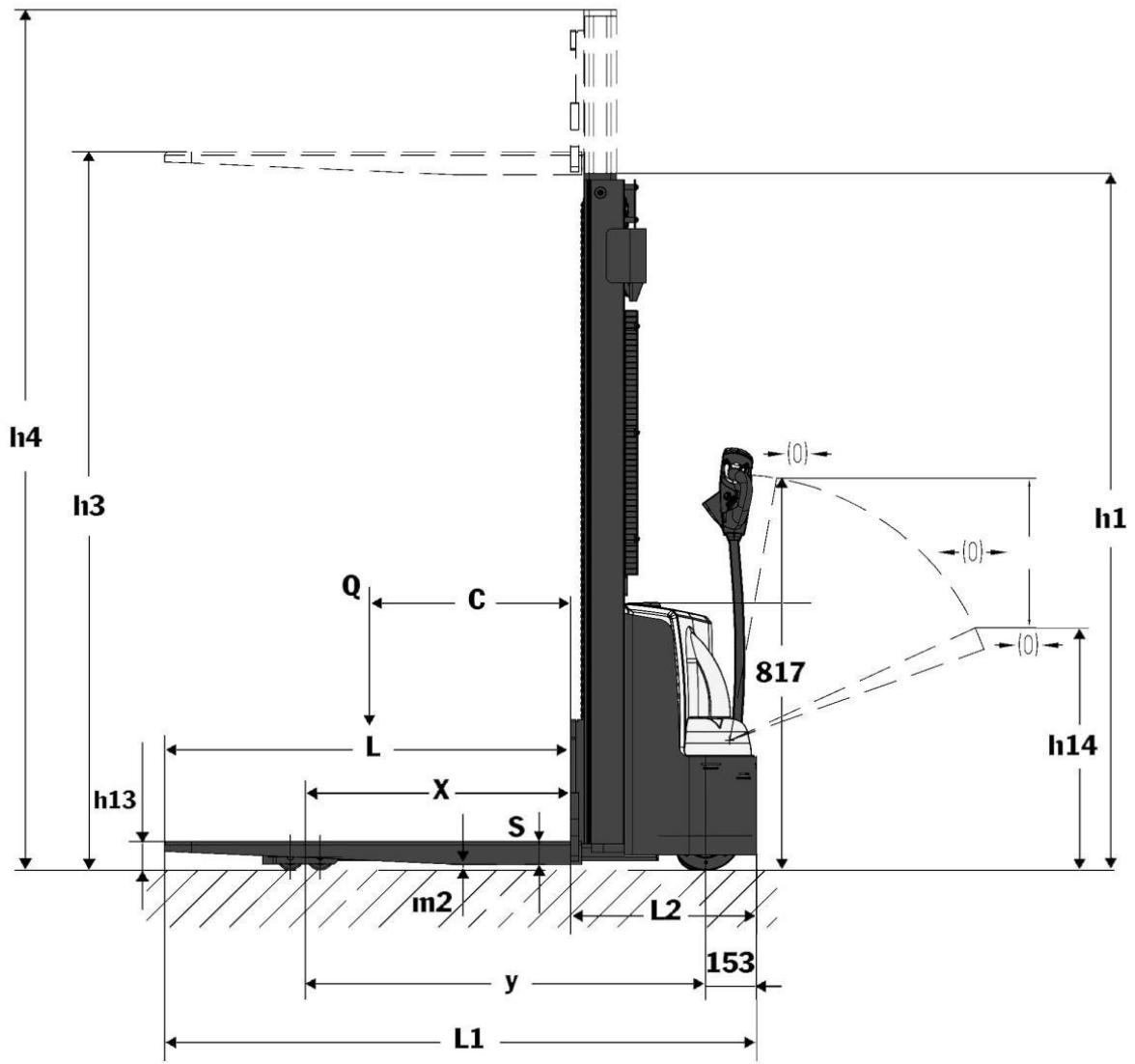

3.2 EN norms



Noise emission: <75 dB(A)

in accordance with EN 12053 as harmonised with ISO4871.

The noise emission level is calculated in accordance with standard procedures and takes into account the noise level when travelling, lifting and when idle. The noise level is measured at the driver's ear.



Electromagnetic compatibility (EMC)

The manufacturer confirms that equipment complies with tolerance levels for electromagnetic emissions and resistance as well as static electricity discharge testing in accordance with EN 12895 including the normative procedures contained therein.



No changes to electric or electronic components or their arrangement may be made without the written agreement of the manufacturer.

3.3 Stability & Vibration

This stacker has been tested for stability in accordance with the ISO 22915-4:2018 standard and meets the requirements of residual risk standards for vehicle overload and overturning.

This stacker is powered by batteries, and the controller is given instructions through the handle, and then the controller outputs instructions to rotate the motor. There is no risk of vibration during this process. So vibration is not evaluated as a typical risk.

3.4 Static testing coefficient for enhancing attachments

This stacker is designed according to the ISO2330-2002 standard. The test load of the fork is 3 times the rated load, and the test load of the chain is 5 times. The test results meet the standard requirements.

4 Identification points and data plates

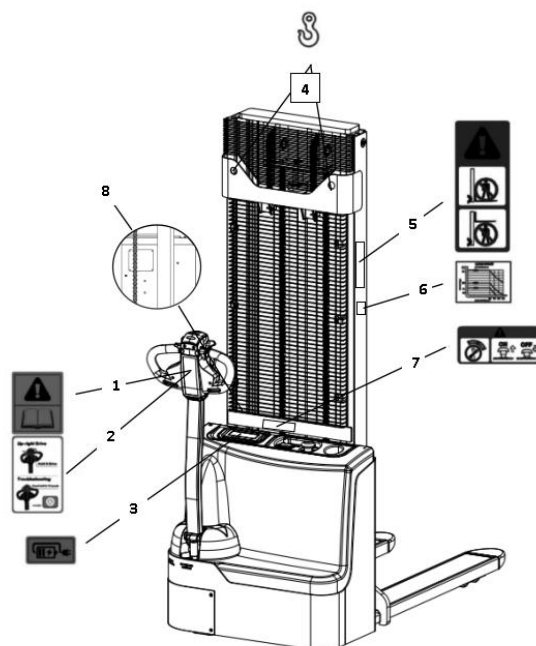

Item	Description	QTY
1	Operation warning	1
2	Handle warning	1
3	Charging warning	1
4	Attachment point for lifting by crane	2
5	"Do not stand on/under the fork" warning	1
6	Load chart label	1
7	Switch ON/OFF warning label	1
8	stacker data plate	1

4.1 Data plate

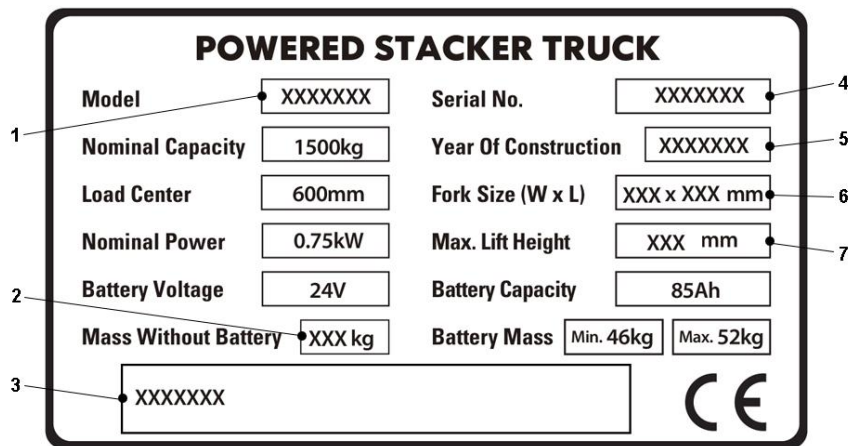

Item	Description	Item	Description
1	Model No.	5	Year of manufacture
2	Net weight excl. battery	6	Outer fork width x fork length
3	Manufacturer	7	Max.Lift Height
4	Serial No.		



For queries regarding the stacker or ordering spare parts, please quote the stacker serial number(4)..

4.2 Capacity



The capacity data with respect to lift height and load centre of gravity distance can be found on the stacker's load chart plate.

The load chart plate to the right shows the capacity (kg) for different load centers of gravity (mm) in diagram form.

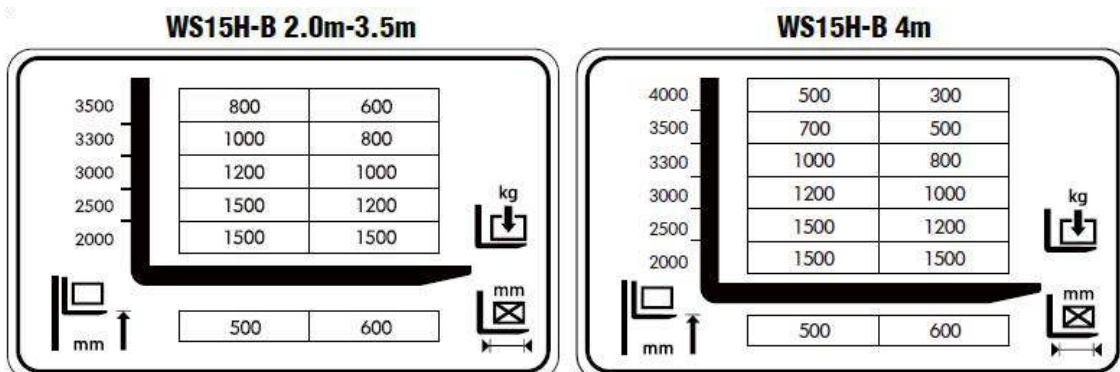

C Transport and Commissioning

1 Lifting by crane



The stacker is designed for short-distance lifting, lowering and transporting load units, not suitable for long-distance travel. If needed, the stacker must be transported by using lifting device or platform to place on stacker or trailer.

- Only use lifting gear with sufficient capacity (for stacker weight see stacker nameplate).
- The attachment points are provided for lifting the stacker with crane lifting gear.
- Park the stacker securely (See Chapter E).
- When hoisting or laying down, it should be stable and slow to avoid collision or accident.



- Park the stacker securely.
- Fasten the harness to the lifting points so that it cannot slip! Crane slings should be fastened in such a way that they do not come into contact with any parts of the stacker when it is being raised.
- Secure the lifting slings to the strap point, and prevent them from slipping. Crane slings should be fastened in such a way that they do not come into contact with any attachments when lifting.
- Load the stacker and park it securely at its destination.

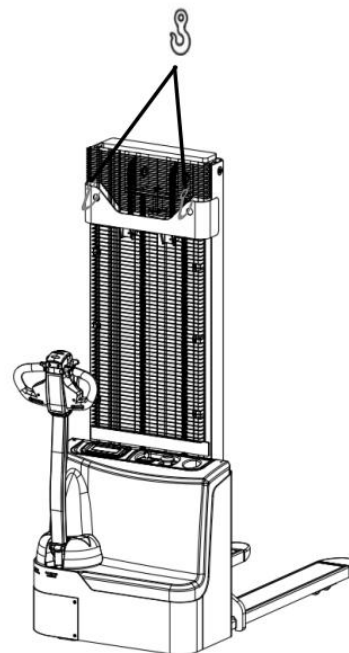

2 Securing during transport



Correctly fix the stacker to avoid move when using stacker or trailer.

- Park the stacker securely.
- Sling the tensioning belt around the stacker and attach it to the fastening rings of the transporting stacker.
- Use wedges to prevent the stacker from moving.
- Tighten the tensioning belt with the tensioner.



- The stacker or trailer must have fastening rings.
- Use wedges to prevent the stacker.
- Only use tension belt or fastening belt of good nominal strength.

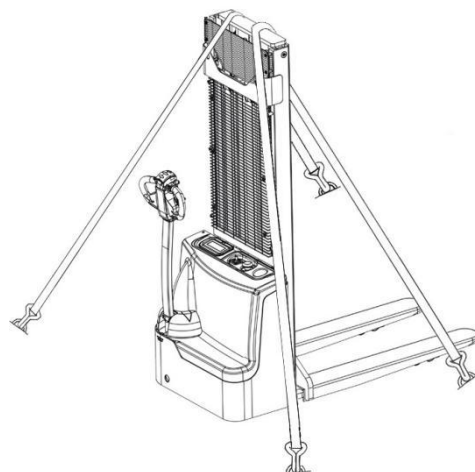

3 Using for the first time



Operate the stacker only with battery current. Rectified AC current will damage the electronic components. The battery leads (tow cable) must be less than 6m in length.



It is forbidden to raise loads if the stacker is operated via a tow lead with an external battery.

To prepare the stacker after delivery or after transport, proceed as follows:

- Make sure the stacker's equipment is complete and in a satisfactory condition.
- Install battery (where required). Do not damage battery cables(see Chapter D).



Set the characteristic curve (charging curve) on the charger (see Chapter D).

- Charge the battery (see Chapter D).
- If necessary, adjust the combination instrument to match the battery type (see Chapter D).
- Commission the stacker in accordance with instructions (see Chapter E).



When the stacker is parked, the surface of the wheels will flatten. The flattening will disappear after a short period of operation.

4 Running-in of new stacker



– The stacker should operate at low load during the initial stage of use, especially within 100 hours, and should meet the following requirements:

- It is necessary to prevent over discharge of new batteries during initial use.
- The prescribed preventive maintenance should be thorough.
- Avoid sudden braking, driving, or turning.
- Limit the weight of the load to 70% to 80% of the rated load.
- During the running-in period, the fasteners of each connecting part should be checked and tightened frequently.
- At the end of the break-in period, the hydraulic oil should be replaced.

D Battery Maintenance, Charging & Replacement



This stacker is equipped with two maintenance-free batteries. The battery has the longest lifespan when the temperature is between 25°C~30°C. Lower temperatures decrease the available capacity of the batteries, while higher temperatures shorten their lifespan.



Battery type: Maintenance-free GEL battery 24V 71Ah/89Ah @5hours

1 Attention for using battery

Park the stacker securely before carrying out any work on the batteries.

Maintenance personnel: Batteries may only be charged, serviced or replaced by trained personnel. The present operator manual and the manufacturer's instructions concerning batteries and charging stations must be observed when carrying out the work.

Fire protection: Smoking and naked flames must be avoided when working with batteries. Wherever a stacker is parked for charging there shall be no inflammable material or operating fluids capable of creating sparks within 2 metres around the stacker. The area must be well ventilated. Fire protection equipment must be provided.

Battery maintenance: Do not place metal objects on the battery, and the battery cell covers must be kept dry and clean. The terminals and cable shoes must be clean, secure and have a light coating of dielectric grease. Batteries with non insulated terminals must be covered with a non slip insulation mat.

Battery Disposal: After the battery is scrapped, please return it to the recycling station for unified disposal and do not discard it arbitrarily. Batteries may only be disposed of in accordance with national environmental protection regulations or disposal laws. The manufacturer's disposal instructions must be followed.



- Before closing the battery cover make sure that the battery lead cannot be damaged.
- When the battery is not used for a long time, please remove it from the vehicle and store it;
- To ensure safety, please use the dedicated charger provided by the supplier to charge the battery;
- The battery should be protected from severe impact, vibration, and compression;
- If the battery needs to be replaced, do not mix old and new batteries.



- When charging externally, do not reverse the polarity of the battery, otherwise it may cause the battery to be scrapped.
- Keep the battery dry and avoid it from getting wet. Do not directly put the battery into water;
- Batteries should be kept away from high temperatures, avoid prolonged exposure to direct sunlight, and it is strictly prohibited to put batteries into fire;
- It is strictly prohibited to change the connection method and purpose of the battery's charging and discharging ports without authorization;
- It is strictly prohibited to directly connect batteries to power sources and loads that do not meet the requirements;
- Try not to use it under overload, high humidity, or steep slopes.
- It is strictly prohibited to leave batteries in a low voltage state for a long time after discharge

2 Battery maintenance

2.1 Maintenance frequency



Daily

After each discharge, the battery needs to be charged in a timely manner. After charging is complete, the charger should be disconnected in time. The cleanliness of the battery should be checked daily, and dust should be removed in a timely job.



Weekly

Visual inspection after recharging for signs of dirt and mechanical damage. If the battery is charged regularly with a IU characteristic curve an equalising charge must be carried out.



Monthly

At the end of the charge the voltages of all cells or bloc batteries should be measured with the charger switched on, and recorded. After charging has ended the specific gravity and the temperature of the electrolyte in all cells should be measured and recorded.

If significant changes from earlier measurements or differences between the cells or bloc batteries are found further testing and maintenance by the service department should be requested.



Annually

In accordance with 2006/42/EC, at least once per year, the insulation resistance of the truck and the battery must be checked by an electrical specialist.



Care of the battery

The battery should always be kept clean and dry to prevent tracking currents.

Any liquid in the battery tray must be extracted and disposed of in the prescribed manner. Damage to the insulation of the tray should be repaired after cleaning. If it is necessary to remove cells it is best to call in the service department for this.

2.2 Battery Storage

If batteries are taken out of service for a lengthy period they should be stored in the fully charged condition in a dry, frost-free room. To ensure the battery is always ready for use a choice of charging methods can be made:

1. A monthly equalising charge.
2. The storage time should be taken into account when considering the life of the battery.

2.3 Battery Maintenance, Faults and solutions

- There is no need to add water for maintenance during normal use of the battery.
- The battery should be regularly checked for damage and leakage, and the surface of the battery should be cleaned.
- Regular checks should be made to ensure that all parts of the battery are securely and reliably connected to avoid sparks or short circuits between the positive and negative poles.
- The battery should always be upright and not upside down. It should also be shockproof and pressure resistant, and installed firmly to avoid severe vibration, collision, and friction of the battery.
- The maximum starting current of the stacker shall not exceed 1.25 times the rated capacity of the battery. For example, the maximum current of a 70A · h battery does not exceed 87.5A. Avoid using situations that result in excessive working current, otherwise it will shorten the stacker's range and battery life.

- Charger matching: The matching of charging parameters of the battery has a significant impact on the performance and lifespan of the battery, so users should choose a high-quality charger with the same charging parameters as the original charger when replacing the charger.
- During the use of the battery, it is necessary to prevent situations such as over discharge, over charging, or under charging, otherwise the battery will be damaged. If possible, the battery should be charged in a timely manner, and it is strictly prohibited to continue driving after the instrument shows that the battery is low; The normal discharge depth should be 50%, generally not greater than 80%.
- When the stacker is not in use, the battery must be charged and stored. It is recommended to charge it once a week when not in use.
- The battery capacity is based on the ambient temperature of 25 °C, and it is normal for the driving range to decrease as the temperature decreases. For every 1 °C decrease in temperature, the battery capacity decreases by approximately 1%, and it is recommended to avoid using it in environments below -10 °C as much as possible.
- The ambient temperature during charging should be controlled between 5 °C and 40 °C, and good ventilation should be maintained. Charging should be done at room temperature in winter to ensure sufficient battery charge.
- The battery is a consumable, and after a period of charging and discharging cycles, its capacity will gradually decrease, causing a gradual decrease in the range, which is a normal loss.

3 Charging the battery

3.1 Charging Cautions

- Park the truck securely (see Chapter E) and starting to charge with **the build-in charger**.
- Before starting charging, check the cable connections and plug connection components for obvious damage.
- The space for charging stackers should be maintained with sufficient ventilation.



– The process of stacker operation is the discharge process of the battery, and excessive discharge of the battery is strictly prohibited. After the stacker is running, the battery should be charged in a timely manner.

- It is strictly prohibited to mix lithium battery chargers and maintenance-free battery chargers.



• This stacker has its own on-board charger and the charger is used together with the battery.. The charging power supply of the on-board charger must be single-phase power frequency AC power supply. It is prohibited to use DC, AC two-phase/three-phase and other non single-phase AC power supplies.

- Please power off the stacker when charging!

3.2 Power interface

- Input voltage: 85Vac~265Vac
- Input frequency: 47Hz~63Hz
- Input current: 1.5A/220Vac, 3.5A/110Vac

3.3 Battery charging



Charging steps:

- Drive the stacker to appointed charging place, park the stacker and render it safe.
- Open the cover(2) of holder and pull out the charging plug (1), then insert it into a suitable power socket.
- Charge the battery until the charging indicator (3) continues to illuminate green.
- Remove the charging plug (1) from the power socket and insert it back into the holder and close the cover(2). After charging, the stacker can now be operated.



- When the battery level is below 20%, charging is necessary.
- When charging, the walking function of the stacker is prohibited.
- Before the battery is fully charged, try not to interrupt the charging process.



Charger LED display

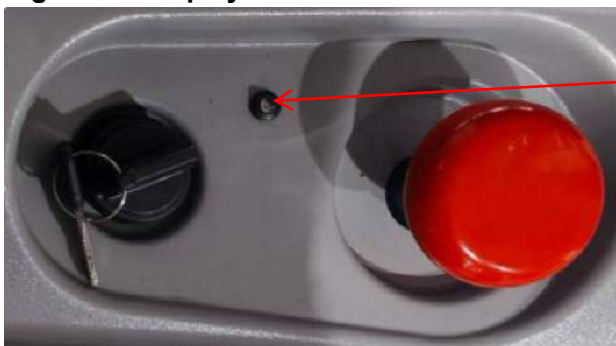

Charger LED display

Flashing Red:	→	Battery Charging
Solid Green:	→	Fully Charged
Flashing Yellow:	→	Charger Fault
Solid Yellow:	→	Battery Fault

4 Battery changed and installation



- The stacker must be parked on level ground.
- When replacing a battery always use the same battery type.
- Extra weights must not be removed and must remain in the same position.

4.1 Battery changed steps



1. Turn off the power: Turn off the key switch (10) counterclockwise, and press the emergency stop switch (11).

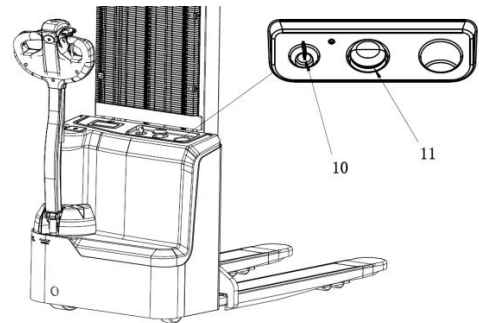

2. Use a 4mm hex wrench to remove the two M6*16 hex screws (8) that secure the ear cover, and then remove the rear cover (9).

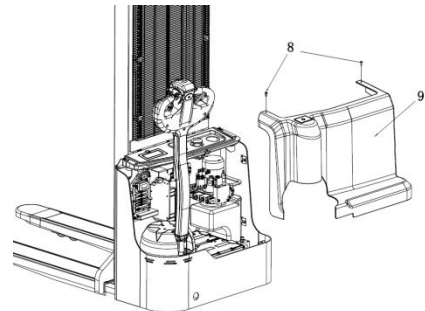

3. Dismantle the batteries:

- Firstly use a 10mm wrench to remove the two M6*16 hex-screws (5&7) and dismantle the positive wire(15) and negative wire(14) respectively, then use a 13mm wrench to remove one M10*25 hex-head screw (12) from the battery mounting plate, and then remove the mounting plate (13).

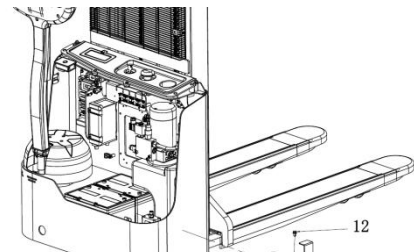

- Use a 10mm wrench to remove the two M6*16 hex screws (3 and 6) and take off the wire that connect the battery (1) and battery (2) in series. Finally, remove these 2 batteries and change the new batteries.

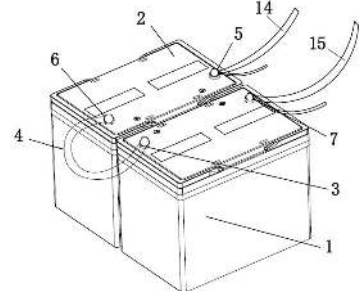

- **Battery installation is in the reverse order of dismantlement. When reinstalling the battery, heed the required installation position and make sure the battery is connected correctly.**
- **After installing the battery again, check all cables and plug connections for visible signs of damage.**

5 Battery charge / discharge indicator



It is easy to find the battery capacity on the display of the handle control box.

When battery capacity <20%, the battery should be charged.



There is no separate battery indicator for this model.

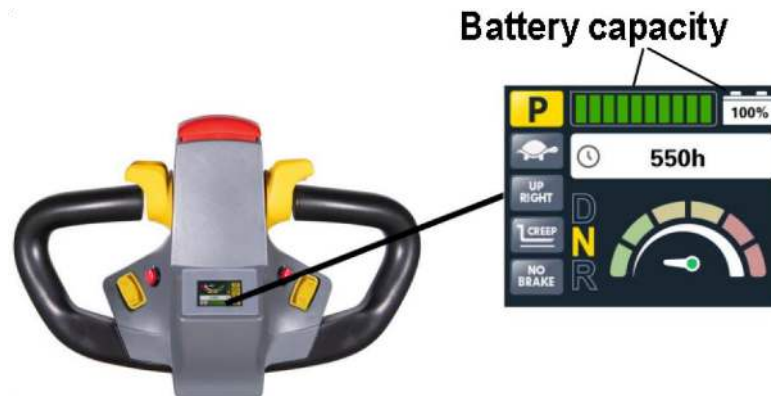

E Operation

1 Safety Regulations for the Operation

Driver authorisation: The stacker may only be used by suitably trained personnel, who have demonstrated to the proprietor or his representative that they can drive and handle loads and have been authorised to operate the stacker by the proprietor or his representative.

Driver's rights, obligations and responsibilities: The driver must be informed of his duties and responsibilities and be instructed in the operation of the stacker and shall be familiar with the operator manual. The driver shall be afforded all due rights. Safety shoes must be worn with pedestrian operated stackers. Travel with a raised load is prohibited (max. height above ground = 500 mm).

Unauthorised Use of stacker: The driver is responsible for the stacker during the time it is in use. He shall prevent unauthorised persons from driving or operating the stacker. It is forbidden to carry passengers or lift personnel.

Damage and Faults: The supervisor must be immediately informed of any damage or faults to the stacker. Stackers not safe for operation (e.g. wheel or brake problems) must not be used until they have been rectified.

Repairs: The driver must not carry out any repairs or alterations to the stacker without the necessary training and authorisation to do so. On no account may the driver disable or adjust safety mechanisms or switches.

Hazardous area: A hazardous area is defined as the area in which a person is at risk due to stacker movement, lifting operations, the load handler (e.g. forks or attachments) or the load itself. This also includes areas which can be reached by falling loads or

lowering operating equipment.



Unauthorised persons must be kept away from the hazardous area. Where there is danger to personnel, a warning must be sounded in good time. If unauthorised personnel are still within the hazardous area the stacker shall be brought to a halt immediately.

Safety Devices and Warning Signs: Safety devices, warning signs and warning instructions shall be strictly observed.

2 Display and control

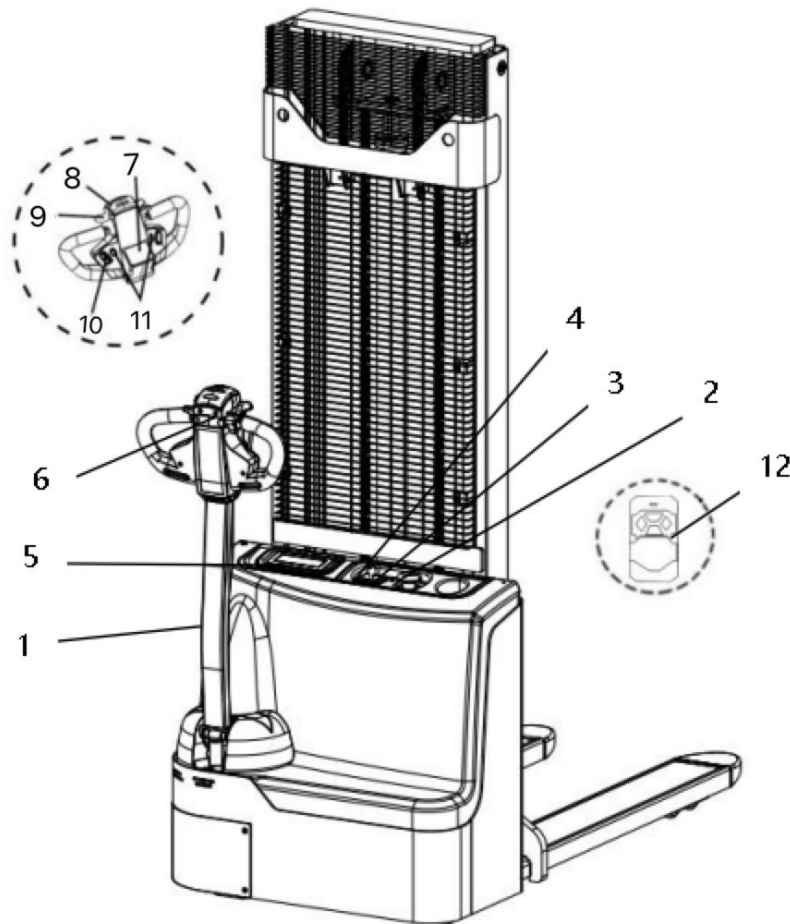

No.	Parts name	Type	Function
1	Handle tube	●	Control steering and braking of the stacker.
2	Emergency stop switch	●	Interrupt circuit, stop all electrical functions. The stacker is forced to brake.
3	Charging LED	●	Display the operating status of the built-in charger.
		●	Flashing red light: charging in progress. Green light always on: charging completed or waiting for battery. Yellow light always on light: battery malfunction. Flashing yellow light: charger malfunction.
4	Key switch assy. (with keys)	●	Activate and deactivate the control current. Removing the switch key lock ensures that the stacker will not start accidentally.

5	Charging plug (Build-in-charger)	●	Charge the battery.
6	Upright walking button (slow switch)	●	Press and hold the turtle speed switch, and the vehicle will move upright. The handle can walk at any angle. Do not press the turtle speed switch, the vehicle is in normal mode, and the handle can only be pressed down to the driving range before walking.
	Turtle speed switch button.	●	Press the turtle speed switch once to enter slow mode. Press the turtle speed switch again to return to normal mode.
7	Display screen	●	1, Display the battery level status; 2, Display the error code; 3, Display the stacker operating status.
8	Emergency reverse button	●	When the safety protection function is triggered by pressing this button, the stacker immediately travels in the direction of the fork for about 3 seconds, and the parking brake is activated. The stacker can only be started again when the driving switch is restored to its initial position.
9	Travel switch	●	Control the direction and speed of stacker travel.
10	Lifting/lowering button	●	Lifting load items.
11	Horn button	●	When horn button is pressed, the horn will ring, as a warning.
12	Remote Control Key	○	With Remote control device for lifting and lowering, maximum driving speed setting, and horn function.

● = Standard

○ = Optional

2.1 Display

→ Charging status indicator[4]

Display of charging status [refer to the charging indicator light display table in Chapter D]



Please refer to the introduction of the handle control box below for the display of the joystick screen.

2.2 Handle control box

→ The manufacturer patented multifunctional intelligent tiller handle is unique design for quick fault diagnosis, enabling an easier service, shorter service time and lowered labor costs.

Multifunctional intelligent tiller handle

- 1 Forward and backward control knob
- 2 Lifting & Lowering
- 3 Fault code display
- 4 Horn
- 5 Emergency reverse switch
- 6 Up-right drive and total speed



Operator Preferred

Turtle Speed — 01

Enable operator to choose different speed modes based on their experience and the specific work environment.

Up-Right Drive — 02

Easily maneuvered with the handle in the vertical position by pressing the turtle-speed button.

Engineering Mode (Brake Release) — 03

When truck is down, release the brake to move the unit manually.

2.3 Control

→ Handle control

- The handle control box is used for steering and braking control.
- When the handle control box is turned left or right, the stacker can be steered in the corresponding direction. The maximum rotation angle of the handle control box is about 175°.
- When the handle control box is pushed down to a horizontal position or pulled up to a vertical position, the stacker can be braked. These two positions are set by the brake micro switch. The default state is open circuit, and the working state is closed circuit. The brake micro switch is normally at the horizontal or vertical position of the handle control box.

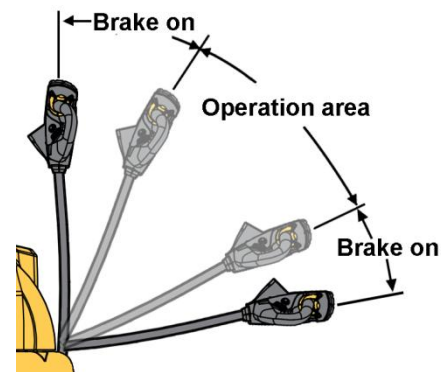
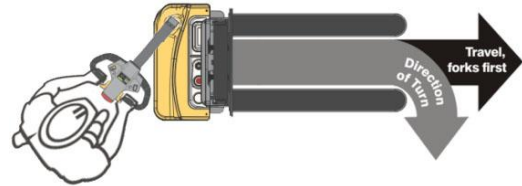

→ Emergency stop switch[2]

Press this switch, power is off. Press it when emergency or no use. If re-start needed, pull upward.

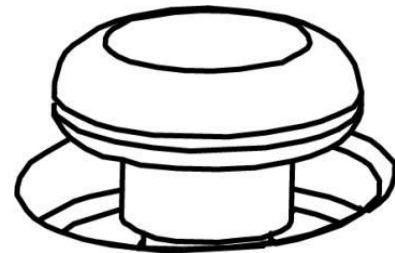

→ Key switch assy.(with keys) [4]

Turn on the key switch, and the power is on.

Turn off the switch, and the power is off.

Turn off the key switch before charging.

The switch lock has two positions, "OFF" and "ON".

When the switch lock is in the "OFF" position, the stacker function is disabled. When the switch lock is turned clockwise to the "ON" position, the power is turned on.

When the driver leaves the stacker, removing the switch lock key ensures that the stacker will not start unexpectedly.

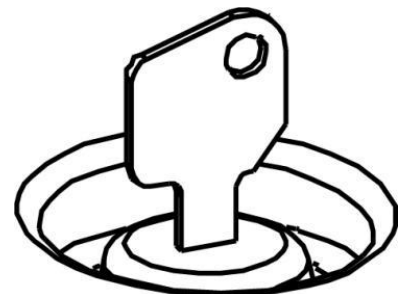



Emergency reverse button[8]

- This switch is at the head of control lever, once touch this button, the stacker moves forward. It is used to protect people from being clamped by the control handle.
- This switch is also called belly switch.

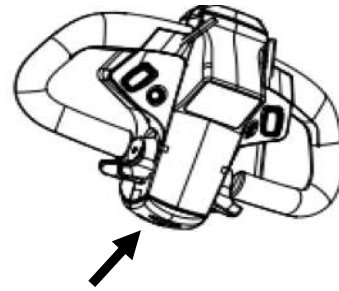

Travel switch[9]

- This button is located on both sides of the control box head, with one linkage on the left and one linkage on the right. It is used to control the direction and speed of operation.
 - The stacker is running towards the fork side
 - Press the control box down with your hand.
 - Thumb the direction and speed control button from one side of the body to the other
 - Gradually rotate outwards.
 - The stacker runs towards the fork side.
- The stacker is running towards the side of the handle (or pedal)
 - Press down the control box. Thumb to control direction and speed.
 - The button gradually rotates towards the side of the body.
 - The stacker runs towards the side of the handle (or pedal).

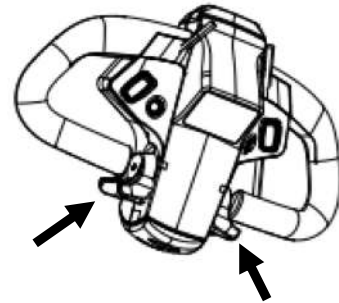

The direction and speed control button will automatically return to its original position when the finger is released, and the stacker will brake. Therefore, the stacker needs to continue running while the finger is not released.

2.4 Optional Configuration-Intelligent control [12]

► Unique in the market and very suitable for sorting operations on stackers.

► With a dedicated remote control device, the operator can control the forks to lift to the appropriate working height and carry out sorting operations, thus avoiding the need to use the handle buttons and bend over to pick up goods, improving operational efficiency and comfort.



- Signal light
- Lifting button
- Max speed setting button
- Lowering button
- Horn button
- On/Off (for Intelligent control)

► With the remote control device, you can easily set the speed suitable for the work, from level 1 speed to level 5 speed.

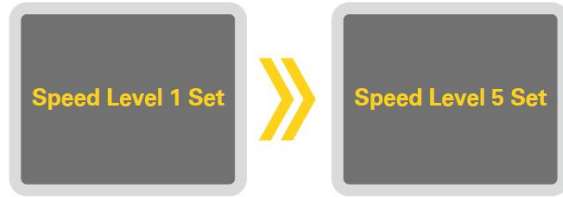

► Such speed transitions allow you to move the stacker with controlled operation at ease.

➔ Instruction for use

- When two or more remote controls are operated simultaneously, there may be signal conflicts.
- Remote control must be operated within 2 meters, otherwise there may be intermittent signal issues.
- When operating remotely, there should be no obstructions in the middle, otherwise there may be intermittent signal issues.
- When operated remotely, the walking and lifting functions of the handle fail.
- Normal operation. Press and hold the remote control lifting or lowering button, the buzzer will sound every 3 seconds, and the button will officially take effect, allowing for the execution of lifting or lowering. Release the button and operate it again within 5 seconds. The button will still work (the buzzer will not beep intermittently) and can be used for lifting or lowering.



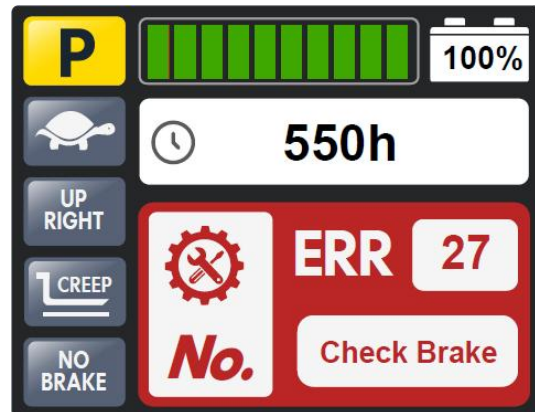

⚠ If not operated for 5 consecutive seconds, the signal will automatically disconnect and the button will fail; To activate, repeat the above steps.

2.5 The tiller handle display

- ➔ – Operation status & fault diagnosis are integrated onto the tiller handle display for easy troubleshooting.
 - Serial communication technology
 - Single wiring harness communication from tiller handle to controller system. Simple, Durable and Stable.
 - Low after-sales service cost
 - Quick & easy fault diagnosis
 - Everyone can be an expert







Signal	Description	Function	How to appear the signal
	Parking	When the stacker is moving, the signal disappears.	This signal appears when stacker parking.
	Turtle Speed	Press the turtle button, the stacker speed slows down to half of the travel speed, press the button again to cancel this function.	This signal appears when pressing the turtle button; press once more, it will disappear.
	Upright driving	Press the turtle button and reverse the acceleration at the same time, then the stacker can be moved upright.	This signal appears when pressing the turtle button and reverse the acceleration at the same time.



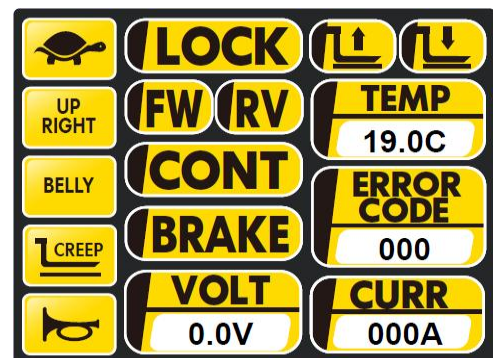







	Speed limitation	When lifting to 440mm height, the signal will appear and the speed will slow down to half of the travel speed, it is a security setting. When lowering below 440mm, the signal will disappear and the speed returns to normal.	No operation required, it will automatically appear when lifted to a height of 440mm.
	Brake Release	With the stacker closed, press and hold the horn switch, then turn on the emergency stop switch and key switch to disable the braking function. So that the stacker crane can only be manually dragged in emergency situations or maintenance.	With the stacker closed, press and hold the horn switch, then turn on the emergency stop switch and key switch, this signal will appear.
	Power indicator display	Battery power indicator display	No operation required, it will automatically appear when turning on the stacker.
	Cumulative running hour display	Hour meter display	No operation required, it will automatically appear when turning on the stacker.
	Fault code display	Error code display	No operation required, it will automatically appear when the stacker is fault.

2.6 Handle self-diagnostic function

➔ Turn on the stacker, press the emergency reverse button cover and the turtle speed switch button simultaneously and hold for 15 seconds, then the display screen will show the diagnostic interface. Release the buttons to enter the self-diagnostic interface.

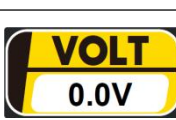

No.	Signal	Description	Function
1		Turtle Speed	Press the turtle button, the stacker speed slows down.
2		Upright Driving	Press the turtle button and reverse the acceleration at the same time, the stacker can be moved upright.
3		Emergency reverse interlock	Press the belly button, the stacker will not move and need to be restarted to move properly.
4		Speed limitation	When the fork lifts to 440mm, the signal will appear and the speed will slow down. When the fork starts to fall below 440mm, the signal will disappear and the speed will be normal.

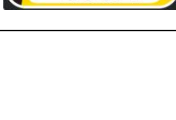
5		Horn	Press the horn button, the signal will appear.
6		Lock	When the stacker in the drive angle, this signal will appear.
7		Forward	When the stacker is moving forward, this signal will appear.
8		Reverse	When the stacker is moving reverse, this signal will appear.
9		Main contactor	When the controller relay is working, this signal will appear.
10		Electromagnetic brake	When the brake is releasing, this signal will appear. When the brake is closing, this signal will disappear.
11		Acceleration voltage	When accelerator is in neutral position, the voltage should be 2.5V. When it is pushed forward, voltage should increase to 4.5V. When it is pushed backward, voltage should reduce to 0.5V.
12		Lifting	When the fork is lifting, this signal will appear.
13		Lowering	When the fork is lowering, this signal will appear.
14		Controller temperature	Current controller temperature
15		Error code	When the stacker has some problem, this error code will show here.
16		Current	Traction motor working current

2.7 Fault and troubleshooting

Fault	Probably cause	Method of Fault eliminating
Signal light brightness is weak	Low battery	Change the battery
The signal light is not on	Not turned on/battery low	1. Confirm if the power is turned on 2. Replace the battery

Occasionally pause during lifting and lowering	Signal instability; There are obstructions in the operating space Not within the remote control range	Operate in an open area within 2 meters
Signal light on, action not executed	Improper operation (such as using too much force on the buttons, causing them to get stuck)/Remote control and handle not matched	1. Standardized operation 2. Re pair with the controller 3. Turn on the remote control function
After successful pairing, the remote control still cannot be used	Remote control function not turned on	Turn on the switch

3 Operating

3.1 Check before operation



In order for the safety stacker operation and keep the stacker in good condition, before starting the stacker, you must check it carefully.

1) Oil leak and liquid leak checking

Park the stacker, and check the stacker for hydraulic oil, gear oil or electrolyte leak.

2) Fork check

Check the fork and see whether bending or crazed.

3) Front/rear wheel and balance wheel check

Check the wheel and see whether there is any crazed, damaged, or abnormal wearing. Check the wheel fasteners for looseness. And inspect whether there is rope on the wheel.

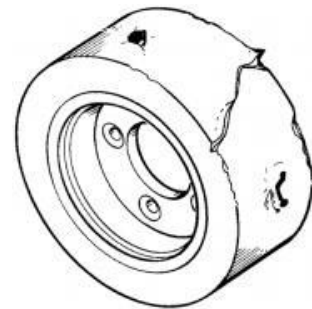

4) Check front fork and linkage mechanism

Check the fork and linkage mechanism, see whether bending or crazed. Whether appear interfere when move, movement point wear whether severe.

5) Hydraulic oil check

Loosen the hydraulic oil filler cap, pull out dipstick, and check if the oil level within the scales. Add oil when insufficient.

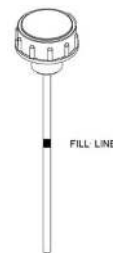

6) Battery check

- Check the battery cover board. See whether the battery fixed reliably.
 - Check the terminal for loose or damage.
- Otherwise adjust or replace

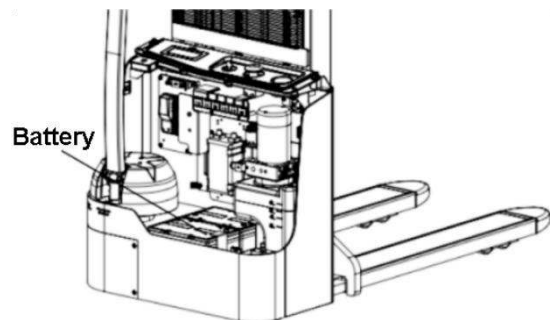

7) Instrument display check

Refer to description of handle control box.

8) Lifting and lowering button

Press the lifting button and check the fork lifting condition. Press the lowering button, check the fork lowering condition. Check if the lifting system has abnormal sound.

9) Forward and reverse running condition

Tilt the handle to some degree, gradually press the accelerator button to the outside of the body with thumb, and inspect the forward running condition; gradually press the accelerator button to the inside of the body with thumb, and inspect the reverse running condition.

10) Brake system

When the stacker run forward or backward, push the handle to vertical position or press to level position to check the brake condition.

11) Steering system

Left or right turn the handle to make the stacker run around 3 turns, and then check if the steering system is normal.

12) Check chain tensiony

- Lift forks up 10~15cm.
- Press the middle of the chain and see if the left & right tensiony is the same.
- Tensity adjustment: screw off the nut ①, adjust nut ② to keep the same tensity of the two chains, and then tighten the nut ①.

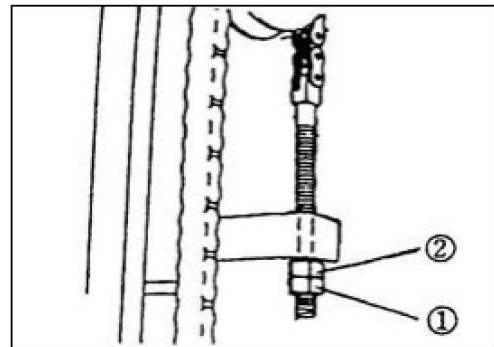

13) Horn

Press the horn button to check sound.

14) Appearance

Check the stacker appearance for clean, rust or paint spalling.

15) Others

Check whether there is any abnormal noise, whether wiring is regular or fastener loosens etc.

3.2 Starting up



Before the stacker can be commissioned, operated or a load unit lifted, the driver must ensure that there is nobody within the hazardous area.

Checks and operations to be performed before starting daily work

- Perform a pre-operation inspection to ensure that all functions and conditions are normal.

Switching on the stacker

- Pull up the emergency disconnect switch(2).
 - Turn on the key switch(4). The handle monitor displays the battery level status.
- Then, the stacker is in a ready operation state.

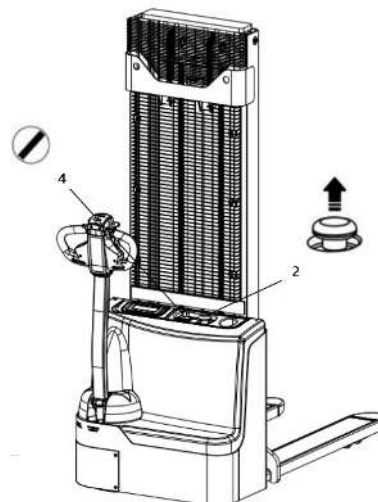

3.3 Using

3.3.1 Safety regulations for operation

Travel routes and work areas: Only use lanes and routes specifically designated for stacker traffic. Unauthorised persons must stay away from work areas. Loads must only be stored in places specially designated for this purpose.

Driving conduct: The driver must adapt the travel speed to local conditions. The stacker must be driven at slow speed when negotiating bends or narrow passageways, when passing through swing doors and at blind spots. The driver must always observe an adequate braking distance between the stacker and the vehicle in front and must be in control of the stacker at all times. Abrupt stopping (except in emergencies), rapid U turns and overtaking at dangerous or blind spots are not permitted. It is forbidden to lean out of or reach beyond the working and operating area.

Visibility when travelling: The driver must look in the direction of travel and must always have a clear view of the route ahead. When carrying loads which affect visibility, these must be stored at the rear of the stacker. If this is not possible, a second person must walk in front of the stacker as a lookout.

Negotiating slopes and inclines: Slopes or inclines may only be negotiated if they are designated traffic routes, are clean and have a non-slip surface and providing they can be safely negotiated in accordance with the technical specifications of the stacker. The stacker must always be driven with the load unit facing uphill. The industrial stacker must not be turned, operated at an angle or parked on inclines or slopes.

Inclines must only be negotiated at slow speed, with the driver ready to brake at any moment.

Negotiating lifts and docks: Lifts and docks must only be used if they have sufficient capacity, are suitable for driving on and authorised for stacker traffic by the owner. The driver must satisfy himself of the above before entering these areas. The stacker must enter lifts with the load in front and must take up a position which does not allow it to come into contact with the walls of the lift shaft.

Persons riding in the lift with the stacker must only enter the lift after the stacker has come to a halt and must leave the lift before the stacker.

Type of loads to be carried: Only transport properly secured loads. Never transport loads stacked higher than the top of the fork carriage or the load guard.

3.3.2 Travelling, Steering, Braking



Never carry passengers.

Emergency Stop

– Pull down the emergency disconnect switch(2), all electrical functions are deactivated.

Automatic braking

Automatic braking occurs when the tiller is released - the tiller automatically sets itself to the upper brake zone (B1 & B2).



If the tiller moves slowly to the brake zone(F), the cause of this fault must be rectified.

Travelling



Travel with raised forks / raised load beyond 500 mm above the ground is prohibited.



Do not drive the stacker unless the panels are closed and properly locked.

– Start up the stacker (refer to section 3).

The travel speed is governed by the travel switch (9).

– Set the tiller (1) to the travel range (F) and press the travel switch (9) in the desired direction (fwd. or rev.).

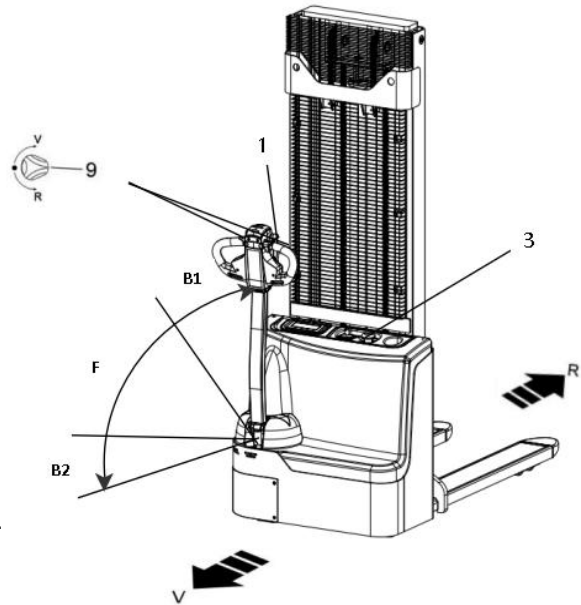

Steering

– Apply the tiller (1) to the left or right.

Braking



The braking pattern of the stacker depends largely on the track conditions. The driver must take this into account when operating the stacker.

Braking with the Service Brake:

– Set the tiller (1) up or down to one of the brake zones (B1&B2).



The service brake is the generator brake. Only when this brake fails to achieve the necessary brake force is the mechanical brake applied.

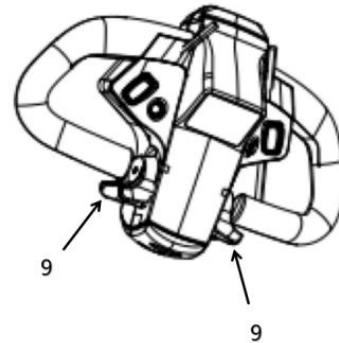

Engineering Mode(Brake Release)

When truck is down, release the brake to move the unit manually.

Plugging:

- You can set the travel switch (9) to the opposite direction when traveling.
- The stacker braked regeneratively until it starts to move in the opposite direction.

Braking with the Coasting Brake:



If the travel switch is set to 0, the stacker automatically brakes regeneratively. In hazardous situations set the tiller to the brake position.

Driving on inclines

Loads must always be carried on the end of the stacker facing uphill.



Preventing the stacker from “rolling downhill”:

– If the stacker is driving on a slope, when the accelerator knob is pushed forward, the vehicle may slip backwards, and the brake will automatically activate after a brief jolt

(the controller detects that the stacker is slipping backwards on the slope). The service brake is released again through the travel switch, which is also used to select speed and direction of travel.

3.3.3 Collecting and depositing loads



Before lifting a load, the driver must ensure that it is correctly palletised and that the capacity of the stacker is not exceeded.

– Drive the stacker with forks as far as possible underneath the load.

Lifting/lowering



– Both lifting and lowering adopt stepless speed regulation function, the lifting/lowering speed can be infinitely controlled,

– Push backward or forward the lifting/lowering button switch until the required lifting height has been reached.

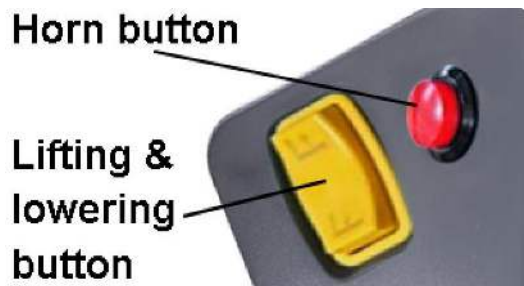
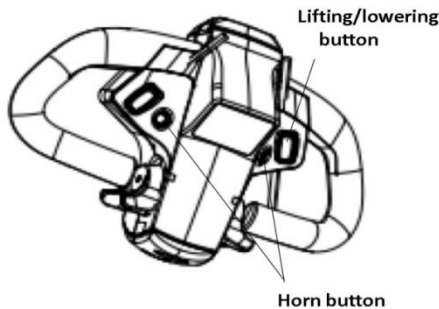

3.4 Parking

When you leave the stacker it must be securely parked even if you only intend to leave it for a short time.

Drive the stacker to safe area or appointed area.



Do not park the stacker on a slope. The load forks must always be lowered to the ground. Lower the load forks.

Turn off the key switch(4), and remove the key.

If park for long time, press the emergency disconnect witch(2).

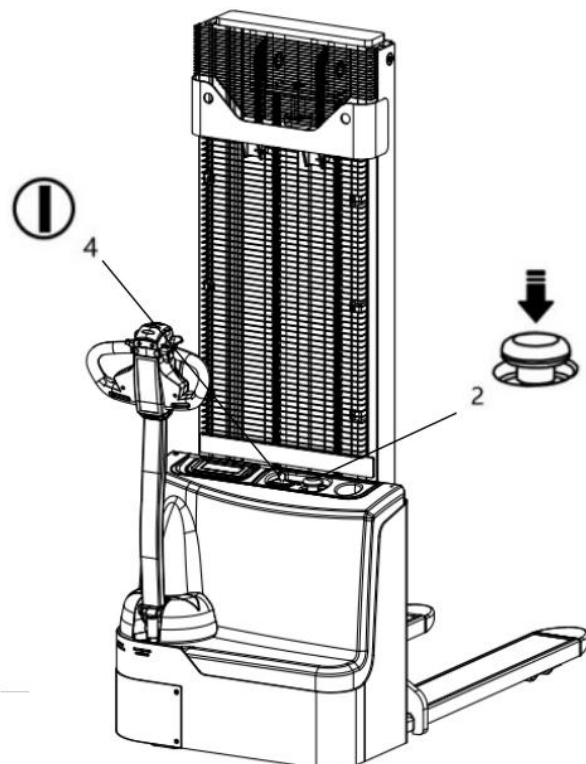

3.5 Deposit the stacker

3.5.1 Deposit the stacker for long time

- Fully check the stacker, especially check the wheel damage.
- Check fluid oil and electrolyte for leakage.
- Apply lubrication grease.
- Check the joint face of cylinder piston rod for looseness, and if scratch on the piston rod surface. Apply anti-rust oil to piston rod or easily rusty axle.
- Cover the whole stacker.
- Check specific gravity of electrolyte and liquid level once a month.
- Do equalizing charge to the battery once a month.

3.5.2 Start running after deposit for a long time

- Remove rust preventive oil on exposed parts.
- Clean impurity and water of the hydraulic oil tank.
- Recharge battery, fit on stacker and connect.
- Carefully check before start. Inspect starting, travelling, slowing down, steering, braking and parking etc. function.

F Maintenance

1 Operational safety and environmental protection

The servicing and inspection operations contained in this chapter must be performed in accordance with the intervals indicated in the servicing checklists.



Any modification to the forklift truck assemblies, in particular the safety mechanisms, is prohibited. The operational speeds of the truck must not be changed under any circumstances.



Only original spare parts have been certified by the quality assurance department. To ensure safe and reliable operation of the forklift truck, use only the manufacturer's spare parts. Used parts, oils and fuels must be disposed of in accordance with the relevant environmental protection regulations. For oil changes, contact the manufacturer's specialist department.

2 Maintenance Safety Regulations

Maintenance personnel: Industrial trucks must only be serviced and maintained by the manufacturer's trained personnel. The manufacturer's service department has field technicians specially trained for these tasks. The manufacturer therefore recommend a maintenance contract with the manufacturer's local service centre.

Lifting and jacking up: When an industrial truck is to be lifted, the lifting gear must only be secured to the points specially provided for this purpose. When jacking up the truck, take appropriate measures to prevent the truck from slipping or tipping over (e.g. wedges, wooden blocks). You may only work underneath a raised load handler if it is supported by a sufficiently strong chain.

Cleaning: Do not use flammable liquids to clean the industrial truck. Prior to cleaning,

all safety measures required to prevent sparking (e.g. through short circuits) must be taken. For battery-operated trucks, the battery connector must be removed. Only weak suction or compressed air and non-conductive antistatic brushes may be used for cleaning electric or electronic assemblies.



If the truck is to be cleaned with a water jet or a high-pressure cleaner, all electrical and electronic components must be carefully covered beforehand as moisture can cause malfunctions.



Do not clean with pressurised water.

After cleaning the truck, carry out the activities detailed in the “Recommissioning” section.

Electrical System: Only suitably trained personnel may operate on the truck’s electrical system. Before working on the electrical system, take all precautionary measures to avoid electric shocks. For battery-operated trucks, also de-energise the truck by removing the battery connector.

Welding: To avoid damaging electric or electronic components, remove these from the truck before performing welding operations.

Settings: When repairing or replacing hydraulic, electric or electronic components or assemblies, always note the truck-specific settings.

Wheels: The quality of wheels affects the stability and performance of the truck. When replacing factory fitted wheels only used original manufacturer’s spare parts, as otherwise the data plate specifications will not be kept.

When changing wheels and wheels, ensure that the truck does not slew (e.g. when replacing wheels always left and right simultaneously).

Lift chains: Lift chains wear rapidly if not lubricated. The intervals stated in the service checklist apply to normal duty use. More demanding conditions (dust, temperature) require more regular lubrication. The prescribed chain spray must be used in accordance with the instructions. Applying grease externally will not provide sufficient lubrication.

Hydraulic hoses: The hoses must be replaced every six years. When replacing hydraulic components, also replace the hoses in the hydraulic system.

3 Servicing and inspection

Thorough and expert servicing is one of the most important requirements for the safe operation of the industrial truck. Failure to perform regular servicing can lead to truck failure and poses a potential hazard to personnel and equipment.



The service intervals stated are based on single shift operation under normal operating conditions. They must be reduced accordingly if the truck is to be used in conditions of extreme dust, temperature fluctuations or multiple shifts.

The following maintenance checklist states the tasks and intervals after which they should be carried out. Maintenance intervals are defined as:

D = Every 8 service hours, or per day

W.= Every 40 service hours, at least weekly

M.= Every 166 service hours, or monthly

T.= Every 500 operating hours, or 6 months

S.= Every 1000 operating hours, or Annually

4 Scheduled maintenance tables

■ = Checks and maintenance to be performed by the operator or the person assigned to truck maintenance.

TO CARRY OUT THESE CHECKS AND MAINTENANCE OPERATIONS, PLEASE REFER TO THE INSTRUCTIONS GIVEN IN THE PARAGRAPHS.

○ = Checks and maintenance operations that should only be performed by a technician authorized by the truck manufacturer

TO CARRY OUT THESE CHECKS AND MAINTENANCE OPERATIONS, PLEASE CONTACT OUR SERVICE CENTRE OR DEALER.

× = Replacement of parts that should only be performed by a skilled technician authorized by the truck manufacturer.

TO CARRY OUT THESE REPLACEMENTS, PLEASE CONTACT OUR SERVICE CENTRE OR DEALER.

5 Maintenance Checklist

Battery

Service item	Service required	Tools	D	W	M	T	S
Storage battery	Battery level		■	■	■	■	○
	Terminal looseness					■	○
	Looseness of connecting wire					■	○
	Cleanness of the battery surface					■	○
	Far away from firing		■	■	■	■	■

Controller

Service item	Service required	Tools	D	W	M	T	S
Controller	Check wear condition of connector					■	○
	Check the running condition of contactor					■	○
	Check interlock inching switch for running			■	■	■	○
	Check the connection among motor, battery and power unit					■	○

Motor

Service item	Service required	Tools	D	W	M	T	S
Motor	Clean the foreign body on the motor			■	■	■	○
	Check the carbon brush and commutator for worn, whether spring is normal						○ or ×
	Whether the connection is correct and firm.						○
	Brush carbon powder on shift plate and shift device.						○ or ×

Wheel (Drive wheel, auxiliary wheel, load wheel)

Service item	Service required	Tools	D	W	M	T	S
Wheel	Check for abrasion or cracks	Eyeballing		■	■	■	○
	Check for bolt fastening and re-tighten.					■	○
	Check if there is foreign body like rope on the wheel			■	■	■	○

Driving system

Service item	Service required	Tools	D	W	M	T	S
Gearbox	Check for noise					■	○
	Check for leakage					■	○
	Add lubricating grease						2years
Steering mechanism	Bearing lubrication					■	○
	Check if the steering flexible				■	■	○
	Check for noise				■	■	○
	Control handle swivel angle				■	■	○

Brake system

Service item	Service required	Tools	D	W	M	T	S
Electromagnetic brake	Check the installation for fastening.				■	■	○
	Check the surface abrasion for equality.					■	○
	Check if the clearance is proper and adjust, if necessary.					■	○or×
	Check the brake for flexibility and effective.		■	■	■	■	○

Hydraulic system

Service item	Service required	Tools	D	W	M	T	S
Hydraulic reservoir	Check for oil level, change oil					■	○
	Clean suction strainer						○
	Clean foreign matter						○
solenoid valve	Check for block, return spring stuck or damage				■	■	○
	Check for wiring looseness.				■	■	○
Safety valve	Check for oil leakage		■	■	■	■	○
	Check for safety valve operation condition.				■	■	○
	Measure safety valve pressure	Oil pressure gauge					○or×
Piping, joint	Check for oil leak, looseness, collapse, deformation and damage				■	■	○
	Replace hoses.						×2~4years
Hydraulic pump	Check hydraulic pump for oil leakage or noise		■	■	■	■	○
	Check pump drive gear for wear						○or×

Lifting inching switch	Check for inching switch work condition.				■	■	○
	Check inching switch for looseness or damage.				■	■	○

Lifting assembly

Service item	Service required	Tools	D	W	M	T	S
Chain & chain wheel	Check chain for tension, damage or rust				■	■	○
	Add lubrication for chains					■	○
	Check chain wheel for deformation or damage					■	○
	Check chain wheel bearing for looseness					■	○
	Pin shaft lubrication					■	○
Lifting cylinder	Check piston rod, rod screw and connection for looseness, deformation or damage	Test hammer		■	■	■	○
	Check for operation		■	■	■	■	○
	Check for oil leak		■	■	■	■	○
	Check lifting cylinder fixed bolt for looseness.					■	○
Mast & fork carriage	Check welded parts of beam and outer and inner masts for defective, cracks or damage					■	○
	Check outer and inner masts for defective weld, cracks or damage					■	○
	Check for defective weld, cracks or damage of fork carriage					■	○
	Check roller bearings for looseness					■	○ or x
	Check rollers, roller pins and welded parts for cracks or damage					■	○
Fork	Check forks for damage, deformation or wear					■	○
	Check fork base and hook welding for defective cracks or wear					■	○
Appurtenance	Check if the status is normal.					■	○

Others

Service item	Service required	Tools	D	W	M	T	S
Wire	Wire damage or looseness				■	■	○
	Looseness of circuit joint					■	○
Emergency stop switch	Check for work condition			■	■	■	○
Direction and speed control button	Check for work condition			■	■	■	○
Lifting, lowering switch	Check for work condition			■	■	■	○
Horn	Check for work and installation condition			■	■	■	○
Handle screen	Check meters for proper operation			■	■	■	○

6 Oil and lubrication

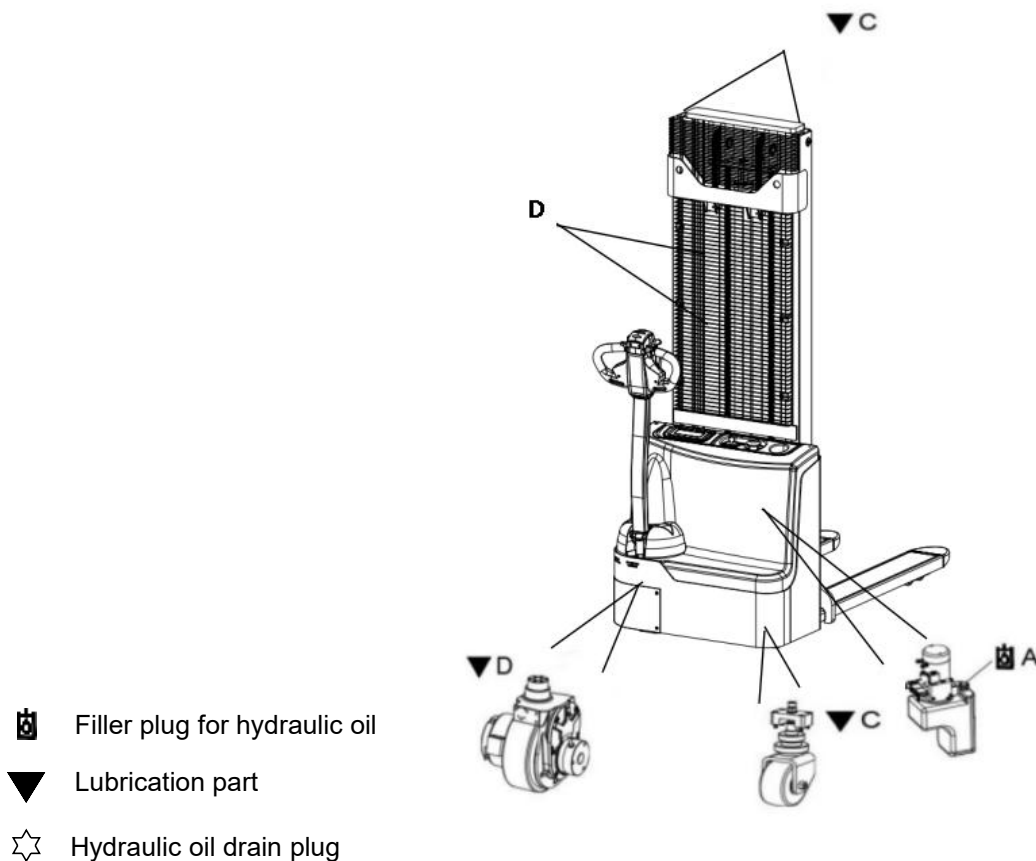

Code	Designation	Mark, code	Remark
A	Hydraulic oil	Normally: L- HM32	Hydraulic system
		High and cold environment:L- HV32	
C	Grease	Automobile general 3 # lithium base lubricant	Nozzle and lubrication
D	Grease	Shell Alvania R3 lubricating grease	Gearbox
E	Chain spray	-	Mast chain

6.1 Replace hydraulic oil

Handling consumables: Consumables must always be handled correctly. Follow the manufacturer's instructions.

STOP Improper handling is hazardous to health, life and the environment. Consumables must only be stored in appropriate containers. They may be flammable and must therefore not come into contact with hot components or naked flames.

Only use clean containers when filling up with consumables. Do not mix consumables of different grades. The only exception to this is when mixing is expressly stipulated in the operating Manual.

Avoid spillage. Spilled liquids must be removed immediately with suitable bonding agents and the bonding agent / consumable mixture must be disposed of in accordance with regulations.

→ Procedure:

- Disconnect the cables of the hydraulic motor, then remove the hydraulic unit. Then remove the 4 screws(No.1) and washers(No.2).

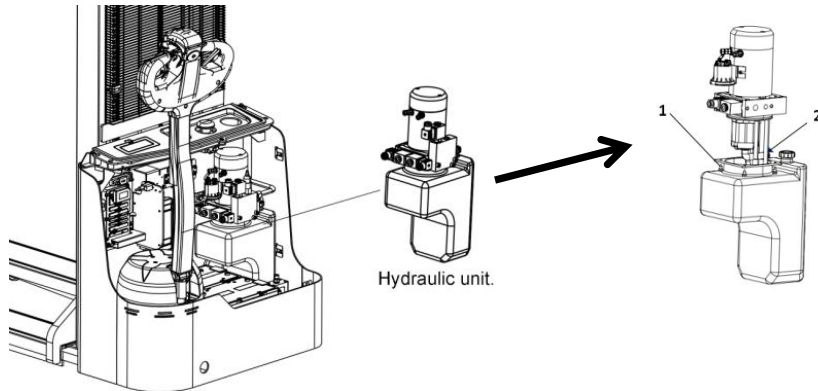

- Loosen the clamp and remove the oil tank.
- Place an appropriate container under the oil tank and pour the hydraulic oil out of the oil tank.

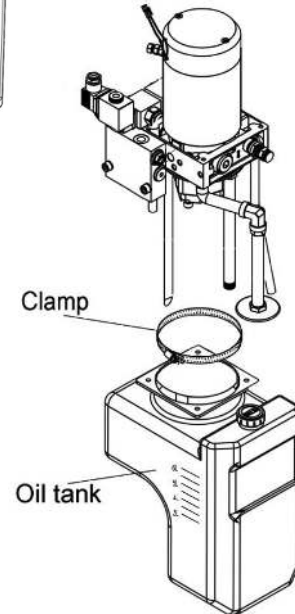

- After oil in the oil tank drains, add appointed gear oil (L-HM32) to allowable scale range. In order to add oil easily, add with help of funnel and tube.

- If only adding some hydraulic oil instead of completely replacing it, you can directly open the oil plug and add oil from the plug.

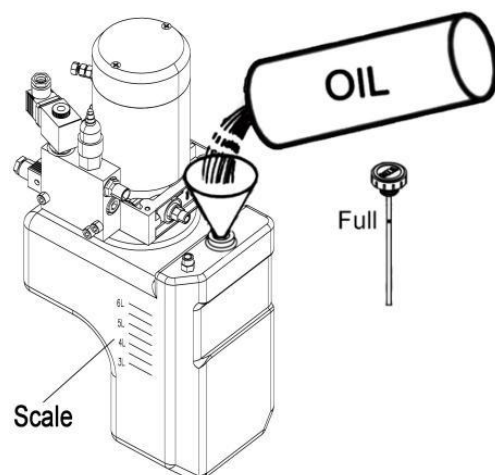
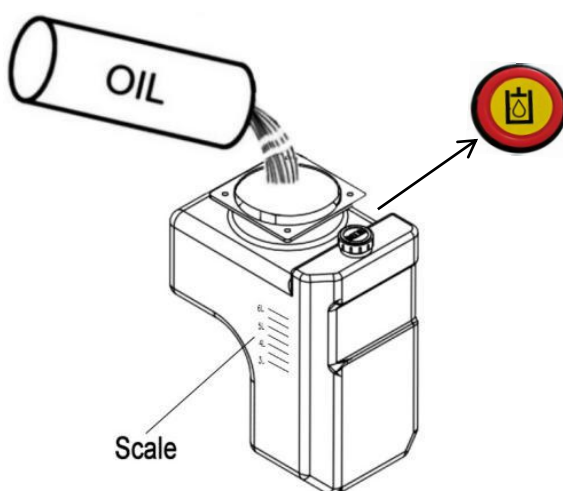

- Re-tighten oil add plug or reorganize into the hydraulic unit assembly, and clean the residual oil on the reduction box surface.

STOP Handle the exhaust oil according to relevant rules of the state and never dump at will.

Refueling quantity:

Lifting height	2000mm	2500mm	3000mm	3300mm	3500mm	4000mm
Refueling quantity	4.0L	4.5L	5.0L	5.5L	6.0L	6.5L

6.2 Replace the key safe parts periodically



Users should replace the parts periodically according to the following table. If the part is abnormal before the replacing time, it should be replaced immediately.

Key safe part's description	Term of using (year)
Hydraulic hose for lifting system	4
High-pressure hose, hose for hydraulic system	4
Inner sealing element, rubber matter of the hydraulic system	2

G Structure, Principle and Maintenance

1 Driving system

1.1 Drive unit structure



This stacker adopts a hub type drive unit (see Figure 2-1). The drive unit has the characteristics of high efficiency, large transmission ratio range, compact structure, and small volume.

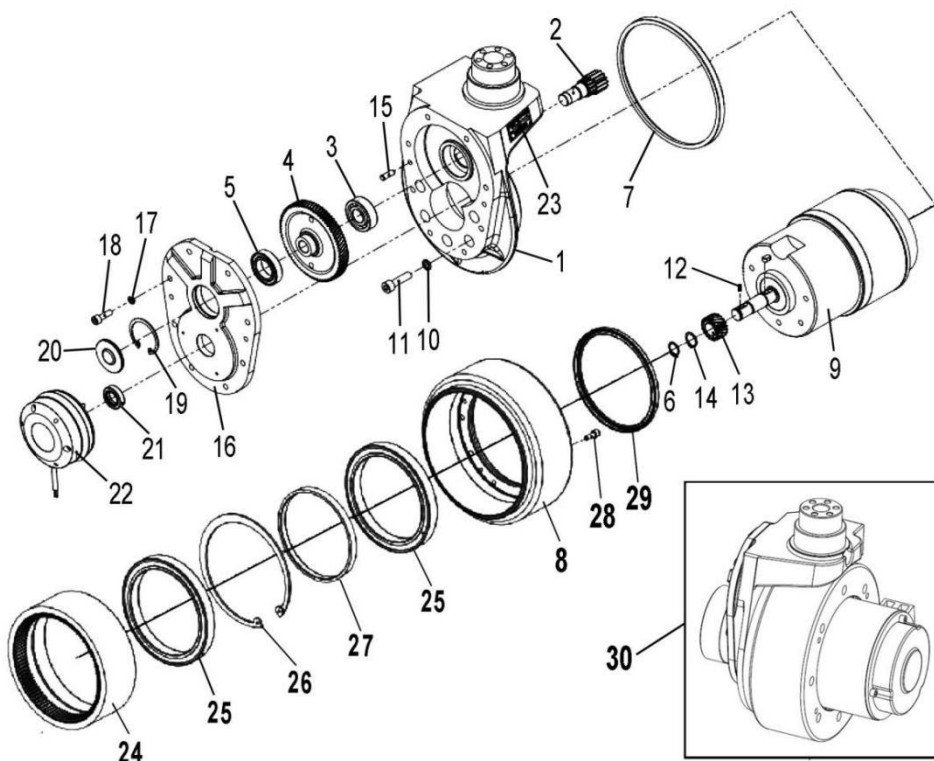

1.2 Working principle

The transmission line of the driving unit is: the driving unit drives the driving gear directly through the motor. The transmission sequence is part 15 (drive motor) → part 13 (driving gear) → part 4 (driven gear) → part 3 (gear shaft) → part 22 (inner gear ring) to drive the drive wheel output. During operation, the driving unit directly relies on the forward and reverse rotation of the motor to achieve forward or backward operation.

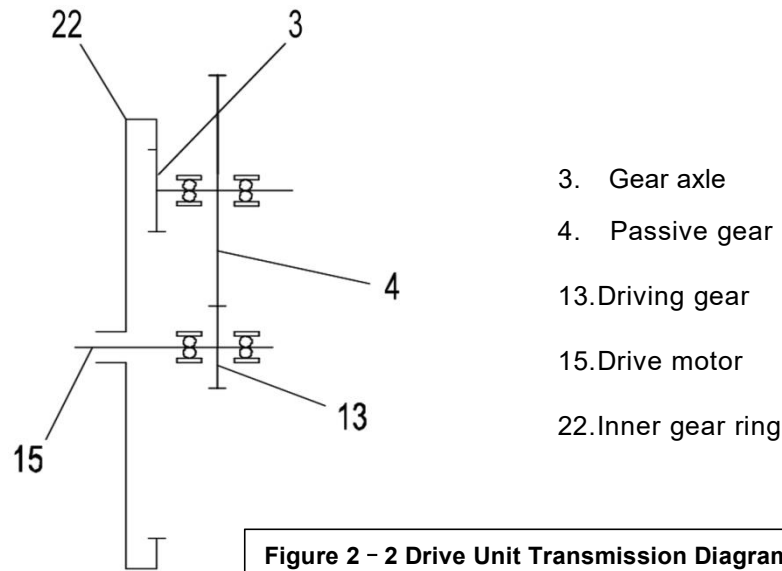

Data:

Reduction gearbox speed ratio			24.685
Maximum torque at wheel edge		N·m	300
Maximum wheel load		kg	1000
Grease			Shell Alvania R3 Lubricant
Weight		kg	37
Drive motor	Rated voltage	V	24
	Rated power	kW	0.75
	Rated current	A	41
	Steering speed	r/min	2650
	Working principle		S2-45min
	Insulation level		F
	Protection grade		IP43
	Operating ambient temperature	°C	- 10~+40
	Service life of electric brushes	h	> 1200
	Rated braking torque	N·m	8
Electromagnetic	Insulation level		F

1.3 Notice to installment and use

- Before installing, you should wipe the oil on the surface of the shell.
- Prevent the assembling surface and exposed flange from being knocked or damaged, otherwise it may influence the installment and use precision.

- The normal operating oil temperature $\leq 70^{\circ}\text{C}$.
- The drive unit is a maintenance free drive device. If lubricating grease needs to be added, the drive unit must be removed and added from the top.
- The injection amount of lubricating grease (Shell Alvania R3 Lubricant) is 2/5-2/3 of the inner cavity.

1.4 Fault and troubleshooting

Fault	Probably cause	Method of Fault eliminating
Abnormal gear noise during driving	Excessive gear clearance	Adjustment
	Lack of lubricating grease	Supplement
	Excessive gear wear	Replace
Abnormal noise during steering	The rolling bearing of the turntable is damaged	Replace
	Insufficient lubrication of the rotary table rolling bearing	Replenish lubricating grease
Poor or ineffective braking	Loose or damaged micro-switch	Tighten or replace
	Excessive brake clearance	Adjustment
	Excessive brake disc wear	Replace
	Brake loose	Fastening
	Line damage	Repair
Excessive vehicle	Damaged shock absorber assembly	Replace

1.5 Drive motor

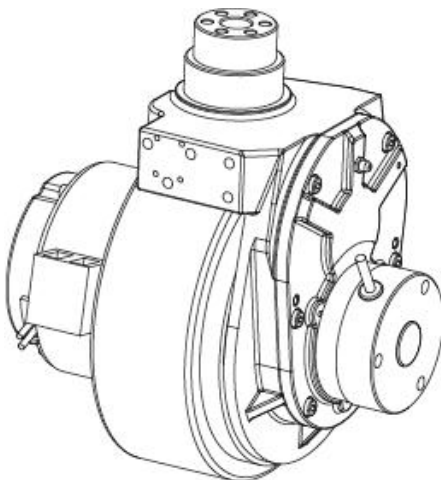

Motor wiring diagram

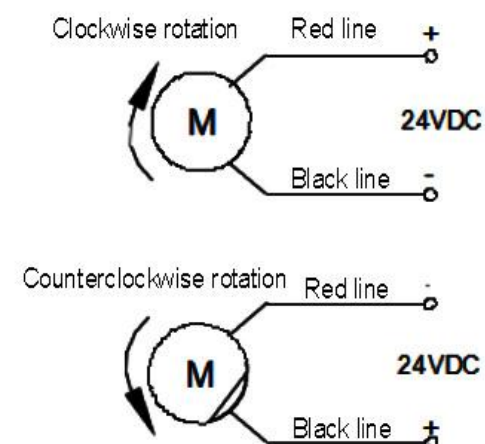

Precautions for motor use

- The surrounding area of the motor should be kept clean and dry, and no other objects should be placed inside or outside.

- Overloading is strictly prohibited.
- It is strictly prohibited to coexist with strong magnetic objects.
- The input voltage level needs to be ensured to be correct.
- If any abnormal odor is found during use, the motor should be immediately stopped for inspection.
- The wiring between the motor and controller should be as short as possible.
- If the motor experiences leakage, sudden decrease in speed, severe vibration, abnormal noise, overheating, smoke, or electrical appliances during operation
- If the contact ignites and emits smoke, it should be immediately powered off and shut down for inspection.



Use and maintenance

Before leaving the factory, all components of the stator have been adjusted, and the neutral position of the carbon brush has been adjusted on the factory test bench. Users are not allowed to disassemble or adjust it arbitrarily

- Check if the armature rotates flexibly and if there is any virtual friction.
- Check if the connection of the motor outlet (or terminal) is correct and secure.
- The electric carbon brush should slide freely inside the carbon brush holder box.
- Check if the commutator space is clean, and if necessary, clean the small grooves between the commutator space and the carbon powder on the commutator surface, which can be soft and free.

A clean white cloth with fluffy threads. If there is grease on the surface, the white cloth can be soaked in alcohol when wiping (parking).

- Check all fasteners for tightness.
- The carbon brush holder must be securely fastened and not loose. If it is necessary to rotate or disassemble the carbon brush holder, markings must be made in order to loosen the end cover screws and carbon brush holder when resetting, align the marked line and tighten the screws to keep the carbon brush in its original neutral position.
- The insulation resistance of the coil should be regularly checked, and when it is close to the working temperature, it should not be lower than the data specified, otherwise it should be dried.

Regularly open the motor end cover and check if the internal parts are deformed and if the commutation part is normal.

- Frequently carbon brush off the sediment and other adhesive substances on the casing to avoid affecting its heat dissipation.
- Check the motor at least once every six months according to the following methods:
 - a. External inspection and removal of dust from the motor;
 - b. Clean or replace the bearings, and carefully listen for any abnormal noises from the bearings during operation;
 - c. Check the wear of the electric carbon brush and replace it if necessary.

Motor fault diagnosis

Fault diagnosis	Probably cause
All copper sheets turn black	Incorrect brush pressure
The reversing pads are grouped in a certain order and blackened	Short circuit between reversing plates
	Armature coil short circuit
	Poor welding or open circuit between the commutation plate and the armature coil
The reversing pad turns black, but there are no certain rules	Displacement of commutator centerline
	The surface of the commutator is uneven and not round
Brushes worn, discolored, and cracked	Motor vibration
	Excessive gap between brush and brush box
	Excessive distance between brush box and commutator working surface
	Mica protrusion between the commutator plates
	Poor brush material
	The brush brand is incorrect
Spark large	Motor overload
	The commutator is not clean
	The commutator is not smooth or circular
	Mica plate or part of the reversing plate protrudes
	Poor grinding of the electric brush
	Insufficient brush pressure
	Wrong brush model
	The brush is stuck in the brush box
	Loose or vibrating brush holder
	The polarity and arrangement of the magnetic poles are incorrect
Heating of brushes and brush braids	Brushes with high sparks
	Poor contact between the brush and the flexible wire
	The area of the soft conductor coil is too small
Brushes have noise	The surface of the commutator is not smooth

1.6 Electromagnetic brake

The brake used in this vehicle is a spring loaded electromagnetic brake. This brake is a single disc brake with dual friction surfaces. By using pressure springs, a strong braking torque can be generated in a power off state, and electromagnetic effects can release the brake.

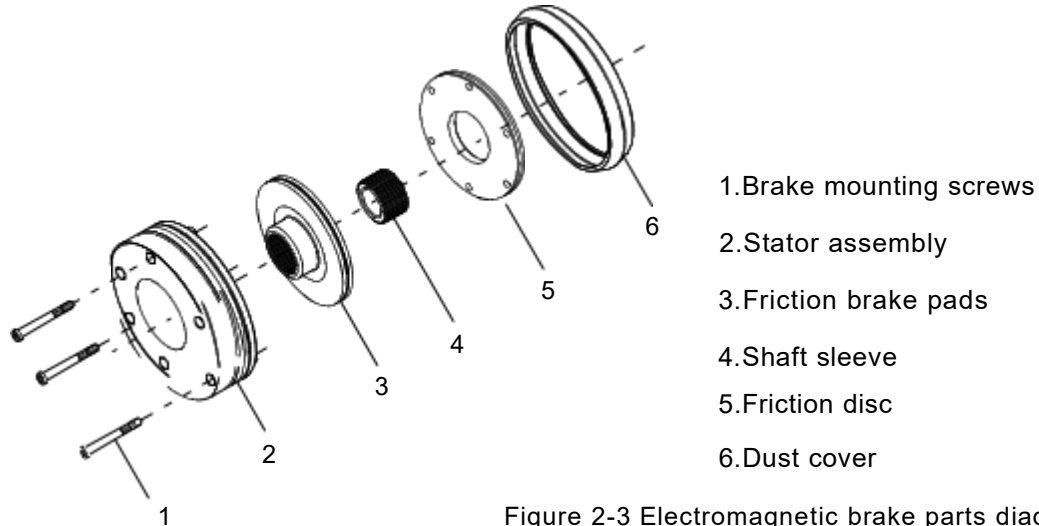
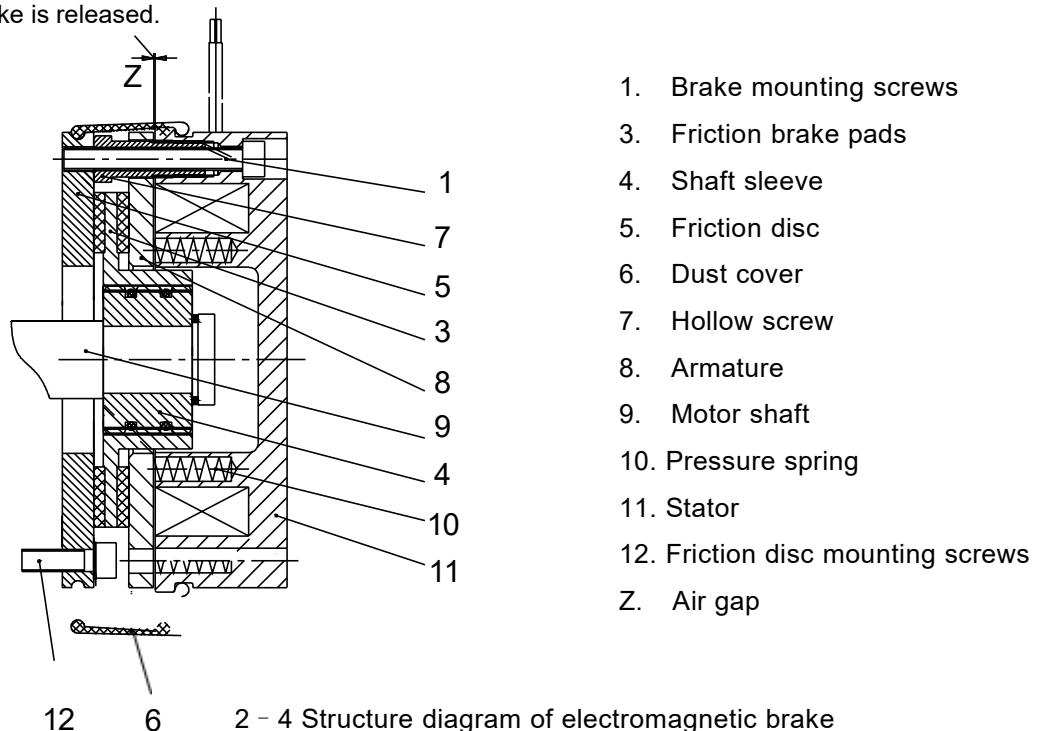

Figure 2-3 Electromagnetic brake parts diagram

1.6.1 Working principle



The motor shaft (9) is connected to the shaft sleeve (4) through a flat key; The shaft sleeve (4) is connected to the friction brake pad (3) through splines. When the stator (11) loses power, the force generated by the pressure spring (10) acts on the armature (8), tightly clamping the friction brake pad (3) driven by the motor shaft to rotate between the armature (8) and the friction disc (5), thereby generating a braking torque. At this point, an air gap "Z" will be generated between the armature and the stator. When it is necessary to release the brake, the stator is connected to direct current, and the generated magnetic field attracts the armature (8) to move towards the stator. When the armature moves, it compresses the pressure spring (10). At this time, the friction brake pad (3) is released and the brake is released.



1.6.2 Brake installment

- Place the flat key (13) into the keyway on the motor shaft (9), press the shaft sleeve (4) onto the shaft (9), and secure it with an internal circlip (14).
- Install the friction disc (5) onto the motor end face using three friction disc mounting screws (12).
- Place the friction brake pad (3) on the shaft sleeve.
- Install the stator assembly (2) onto the friction disc (5) using three brake mounting screws (1).



Before installation, remove the three transport fixing rubber pads from the stator assembly.

- Tighten the three brake mounting screws (1) with a torque wrench (15) and check the brake air gap "Z" with a feeler gauge (16).

- Put on the dust cover (6).

- Connect brake wiring.



- No damage on the outer of wire to avoid circuit damage.
- Never process the locating face and hold of the product to avoid magnetic return path.
- Mount on the motor shaft lightly, no damage the friction surface, get rid of burr from mounting hold and face, install shaft sleeve on the shaft, and fix with snap spring.
- Measure brake connected DC voltage and compare it with the voltage given on the nameplate. Deviation within 10% is allowable.
- During brake install and use, do not stain oil.

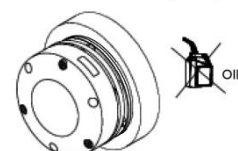
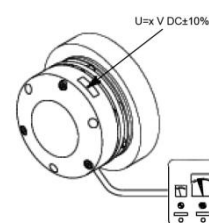
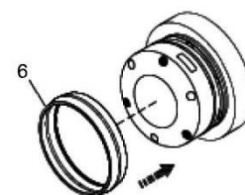
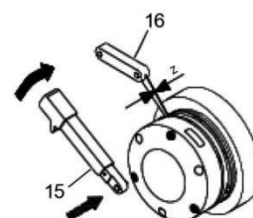
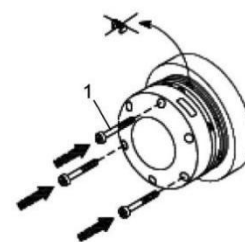
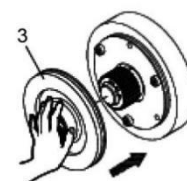
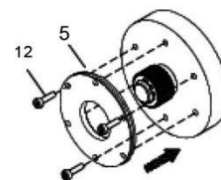
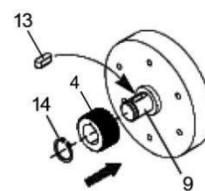

1.6.3 Maintenance

- If work in high temperature environment for long time, please prevent rust, it may influence use if there is rust on the suction surface.
- Do not touch the friction surface with hand, no oil stain, otherwise it cannot reach the maximum torque.
- General use environment temperature is $-10^{\circ}\text{C}\sim+40^{\circ}\text{C}$.
- Please check periodically, and the check item : if the switch motion is normal; if there is noise; if there is abnormal heating; if any impurity, oil stain mixed into friction part or rotating part; if clearance of friction part is proper, exciting voltage normal.

1.6.4 Brake air gap adjustment

- Rated air gap "Z" will be large for wear. Make sure the brake get enough brake torque, readjust air gap before the air gap reach the largest air gap value. Air gap can be adjusted repeatedly, when the thickness of friction braking plate reaches the allowable minimum thickness (refer to specification table), replace the friction disk assembly.
- When the air gap exceeds maximum air gap value, it may cause the brake unable to release, friction braking plate burn out, braking force or retentivity decreases, noises increase, or even cause severe accident. So it needs periodic check and re-adjust the air gap, and it must cut off the truck general power.
- In the case of power outage of the brake, adjust the air gap between the stator (1) and the armature (2) to the rated value "Z" by adjusting three hollow screws (8) and the stator mounting screws (9), and use a feeler gauge to ensure that the air gap is the same in all directions.



Specifications sheet

Rated torque	Rated power	Rated air gap	Max. air gap	Rotor min. thickness	Tightening torque of mounting screw
8N·m	25W	0.2mm	0.5mm	6.4mm	5.5N·m

In the event of power failure in the brake, adjust the three brake mounting screws (1) and hollow screws (7), and use a feeler gauge to adjust the air gap between the stator (11) and the armature (8) to the rated value "Z", ensuring that the air gap is the same in all directions.

The adjustment steps are as follows:

- Use an Allen wrench to loosen the brake mounting screw (1).
- Use a wrench to adjust the hollow screw (7).
- Tighten the three brake mounting screws (1).

- Use a feeler gauge to check if the brake air gap "Z" meets the requirements.
- Adjust the three installation screws and hollow screws according to the diagram, adjust the air gap "Z", and then tighten the brake installation screws.

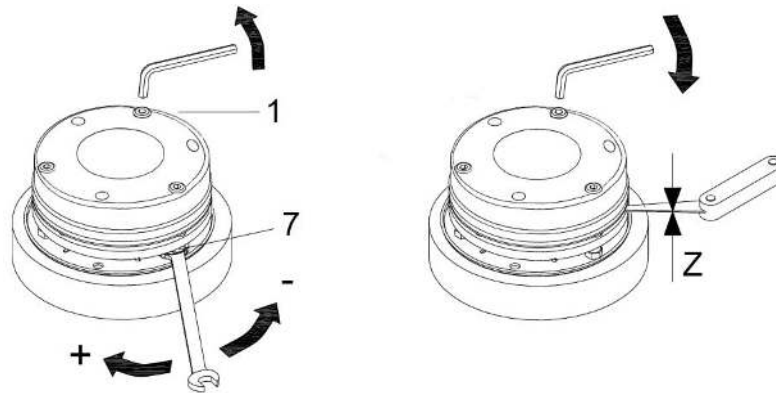

In general working condition, the first air gap adjustment should proceed after brake working for 1500~2000hours, frequency of air gap adjustment is every 6 months. In severe working condition, like frequently brake, repeatedly sudden brake, the first adjustment can be shortened and adjust the interval.

1.6.5 Braking principle diagram

The forklift traveling motor is equipped with an electromagnetic brake. When the forklift stops, the electromagnetic brake is released, and the brake pads firmly lock the motor shaft, leaving the vehicle in a mechanical braking state.

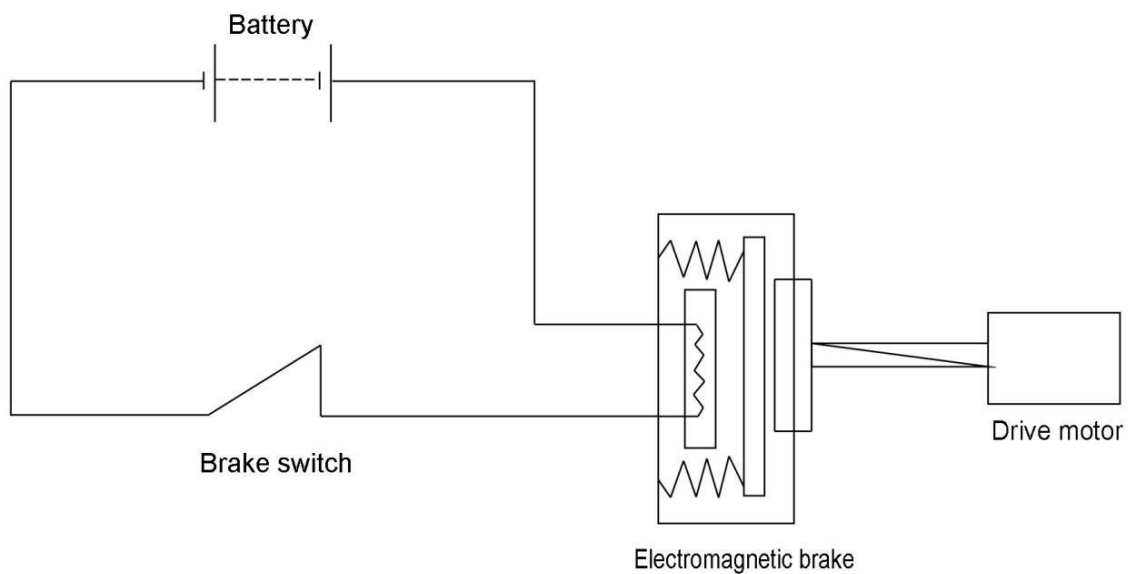

1.6.6 Common fault and troubleshooting

Fault	Probable cause	Corrective action
Brake does not work	Power is obstructed	Connect
	Too low exciting voltage	Check voltage and adjust.
	Improper air gap	Adjust air gap
	Stator coil breaks	Replace stator
	Oil dirt mixed in	Clean oil dirt
Long brake time	Switch installed to AC circuit	Install the switch to the DC circuit after rectifying
	Improper air gap	Adjust air gap
	Oil dirt mixed in	Clean oil dirt
Slipping	Unstable operation in previous use	Running-in for a while
	Oil dirt mixed in	Clean oil dirt
	Large load	Reduce load or replace large specification
	Large load change	Adjust load peak or large the specification
High temperature	Too high exciting voltage	Check voltage and adjust.
	Clutch or motor interfere to the brake	Check control circuit, eliminate interference
	High environment temperature	Set ventilation
	High operating frequency	Adjust to proper frequency
	Over large load	Reduce load
Large noise	Product service environment needs silence	Silence design
	Impurity mixed in	Clear away the impurity
	Bad mounting	Replace mounting surface or shaft
	Large rotational inertia or dynamic unbalance value	Reduce rotational inertia or dynamic unbalance value

2 Hydraulic system



Hydraulic system is mainly composed of hydraulic unit, lifting cylinder and rubber tube etc.

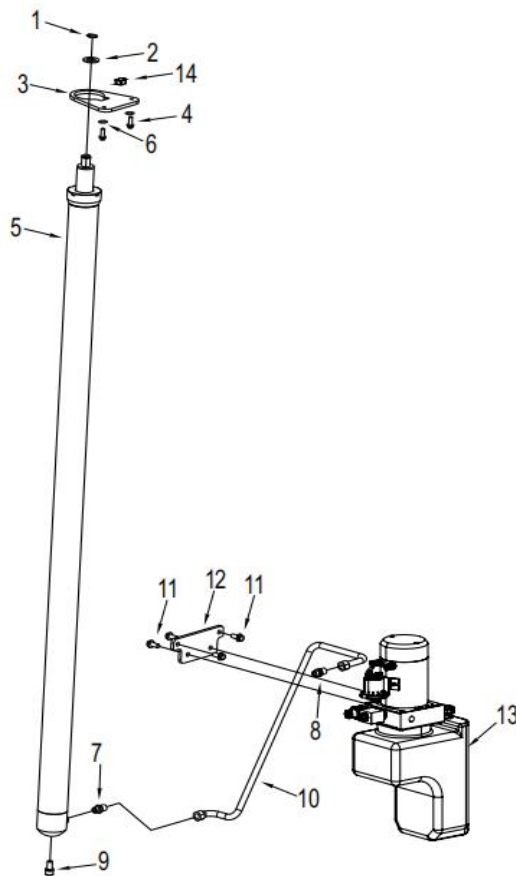

1. Circlip 20
2. Flat washer 20
3. Cylinder retainer plate
4. Screw M8x25
5. Cylinder assy.
6. Oil return pipe connector
7. Oil return pipe
8. High-pressure oil pipe connector
9. Screw M12X25
10. High-pressure oil pipe
11. Screw M10X25
12. Mounting plate
13. Hydraulic unit
14. Cylinder head block

2.1 Hydraulic system working principle

Lifting load

- Press the lifting button on the control box to start the oil pump motor and transmit torque from the motor to the gear pump through the transmission shaft. The gear pump sucks hydraulic oil out of the oil tank and enters the lifting cylinder through a one-way valve. High pressure oil drives the piston rod to move, thereby driving the fork and load up.
- Press the lowering button, the oil pump motor stops running, the gear pump stops suction, and the one-way valve closed, thus keeping the lifting cylinder and load in the lifting position unchanged.
- When the lifting cylinder piston reaches the end position or the vehicle is overloaded, the pressure will exceed the safety pressure set by the relief valve. At this time, the relief valve opens and hydraulic oil flows back to the tank.

Lowering load

- When the lowering button on the control box is pressed, the normally closed electromagnetic directional valve is energized and the return oil channel is opened. The hydraulic oil in the lifting cylinder flows back to the oil tank through the electromagnetic directional valve and speed limit valve under gravity, causing the cylinder to lower and the load to decrease.
- The speed limit valve is designed to prevent the load from dropping too quickly, causing danger such as damage to the vehicle or load.

2.2 Hydraulic Schematic Diagram

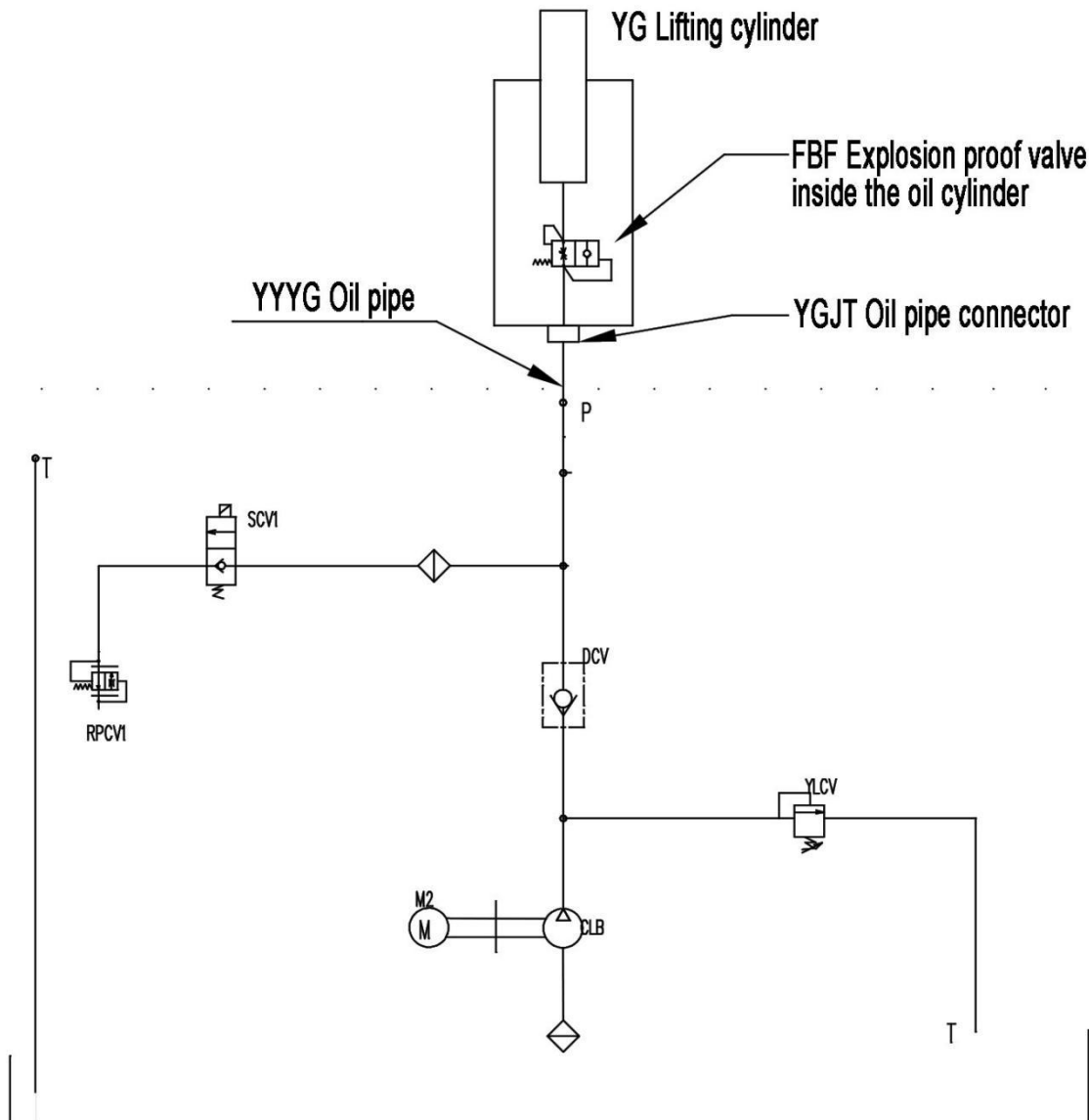

Hydraulic unit assy.

Hydraulic component description										
Code	YG	FBF	YGJT	YYYG	YLCV	DCV	CLB	M2	RPCV1	SCV1
Name	Lifting cylinder	Explosion proof valve	Oil pipe connector	Cylinder oil pipe	Relief valve	Check valve	Oil pump	Hydraulic motor	Pressure compensation valve	Solenoid valve 1
Data	Dia.55	Block traffic 70±5L/min		1SN/16 /13.0MP	Max. flow 18L/min	Max. flow 30L/min	2.5ml/r	24V,2.2 KW	2L/min	Max. flow 18.9L/min

2.3 Hydraulic unit

The stacker adopts combined hydraulic unit(Fig.2-7), and is composed of DC motor, coupling, valve board and valves, oil pump and fuel tank etc.

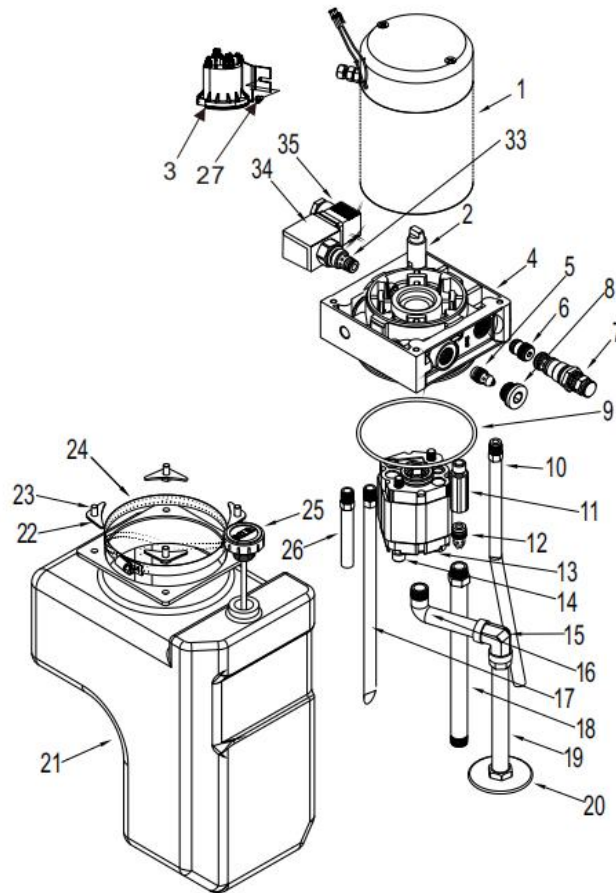

Specification

Hydraulic motor	Rated power	2.5 kW
	Rated voltage	24 VDC
	Working system	S2=1.5min
	Working system	S3=4%ED
	Rotation direction	Rotate in counterclockwise
Oil pump	Rated current	3.4 ml/r
Solenoid valve		24V DC normally-closed valve element
Drop throttle valve		2.8.12 L/min
Thread		G3/8"
Safety valve (overflow valve)		18.0 MPa
Oil suction filter filtration accuracy		250 μm
Hydraulic oil		- 10°C~+70°C

2.4 Hydraulic System Fault Diagnosis and Correction

Fault		Possible reasons	Corrective action
No oil output from the oil pump		Low oil level in the fuel tank	Fill to the specified oil level
		Filter clogged	Clean the oil circuit and fuel tank. If the hydraulic oil is dirty, replace it
Low oil pump output pressure		Bearing wear; Damaged retainer and O-ring	Replace faulty parts
		Safety valve adjustment error	Use a pressure gauge to increase the pressure
		Air in the oil pump	Add hydraulic oil to the fuel tank and wait for the bubbles to disappear before using the oil pump
Oil pump emits noise		Cavitation due to filter screen blockage	Adjusting or replacing hoses and cleaning filters
		Cavitation caused by high viscosity of hydraulic oil	Replace with new hydraulic oil with viscosity suitable for the operating speed of the oil pump, and only operate when the oil temperature is normal
		Bubbles in hydraulic oil	Check the cause of bubbles first, and then take measures
Fork cannot rise	Gear pump has action	Blocked or damaged oil circuit	Repair or replace
		Loose or damaged lifting micro-switch	Resecure or replace
	Gear pump no action	Motor or circuit failure	Overhaul
Fork does not lower		The solenoid valve is blocked or damaged	Repair or replace
The pressure of the safety valve is unstable or cannot be adjusted		Loose pressure regulating screw	Adjust the pressure again and lock it tightly
		The pressure regulating spring is deformed or damaged	Replace
		Worn or stuck safety valve core	Replace or disassemble and reassemble
		Pump failure	Maintenance pump

3 Electrical system



The electrical system of this car is a dual wire system, and all circuits are not grounded. The working voltage of the entire vehicle circuit is DC24V.

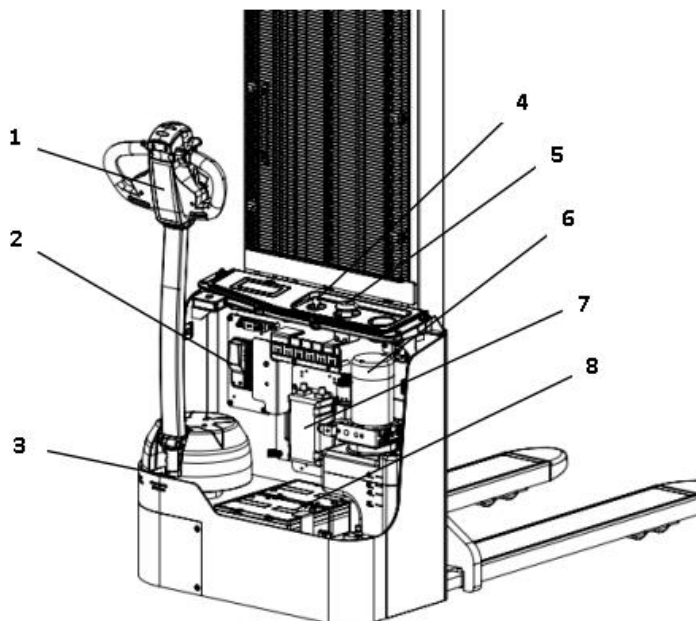

1. Handle assy.
2. Controller
3. Drive unit assy.
4. Key switch assy.
5. Emergency stop switch
6. Hydraulic unit assy.
7. Charger
8. Batteries

3.1 Electrical Schematic diagram

3.1.1 Electrical Schematic diagram for stacker with GEL battery

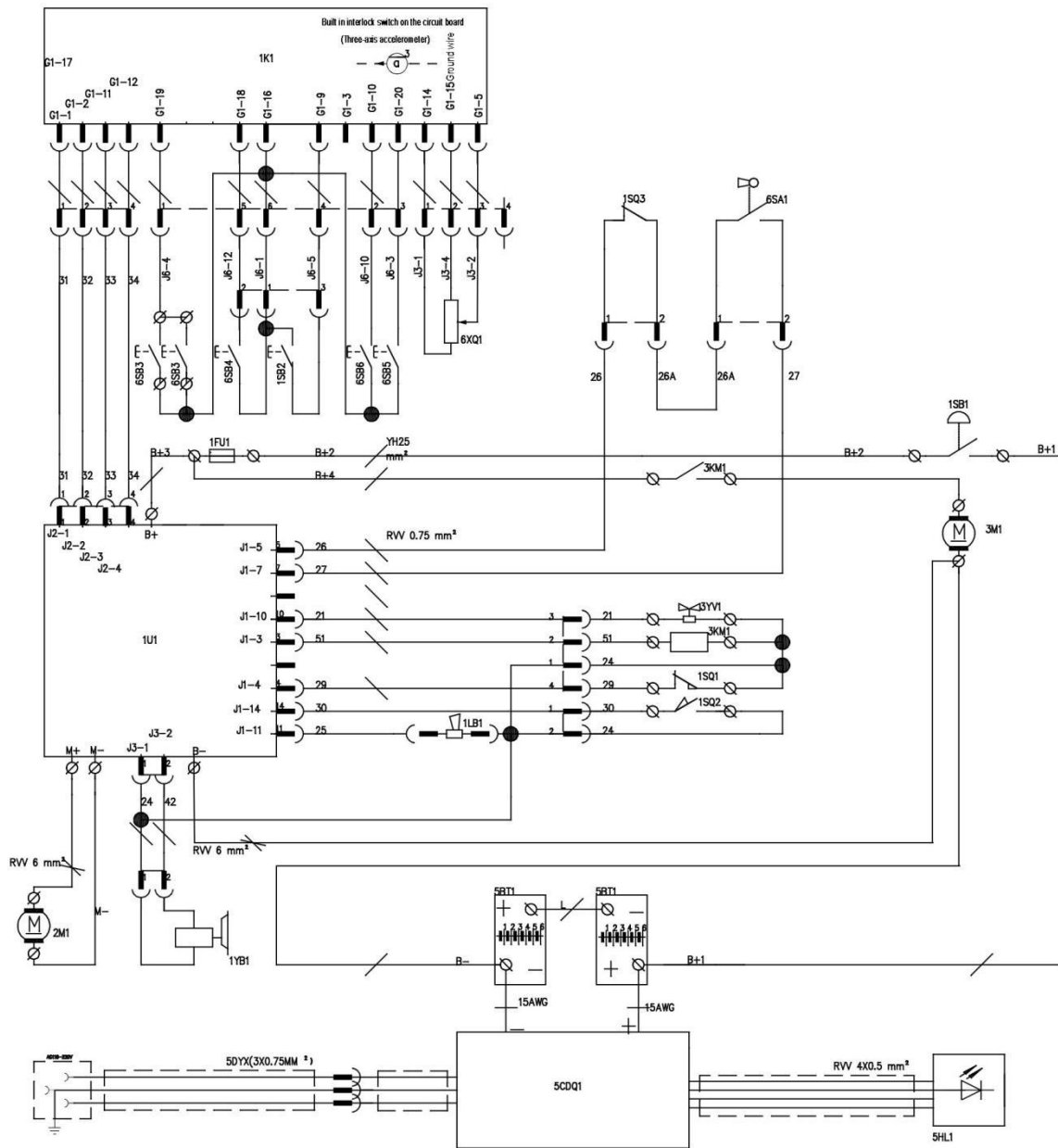

Safety component description													
Code	1SB1	1FU1	1SB2	1LB1	1SQ1	1SQ2	1YB1	1SQ3	1U1	1K1			
Name	Emergency stop switch	Fuse	Emergency Reverse button	Horn	Lifting speed limit switch	Lift limit switch	Brake	Charger limit switch	Controller	Display screen circuit board			
Data	DC24V 125A	200A	5A	105Db	5A	5A	8N.M	5A	Drive 90A Lift 300A	DC14V UART communicate			
Electrical component description													
Code	2M1	3M1	3YV1	3KM1	5BT1	5CDQ1	5DYX	6SB3	6SB4	6SB5	6SB6	6XQ1	6SA1
Name	Drive motor	Hydraulic motor	solenoid valve 1	solenoid valve 2	Battery	Charger	Power line	Horn button	Slow button	Lifting button	Lowering button	accelerator	Key switch
Data	DC24V 0.75KW	DC24V 2.5KW	2l/min	8l/min	Li-battery or lead-acid battery	15A/10A	0.75/1.5mm² wire	5A	5A	5A	5A	0~5V	Ø22 5A

3.2 Drive controller

3.2.1 Controller port and function

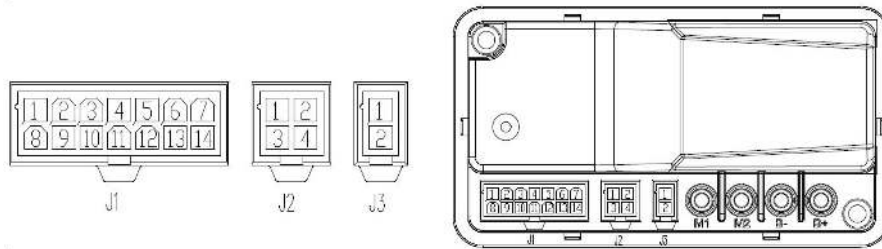

Detailed description of the controller port definition (from the perspective of the direction of the plug in line and the outline)									
J1						J2		J3	
(Reserved)	(Reserved)	Lifting output	Mode switch input	Key switch input	(Reserved)	Logic input positive pole	RX	Low potential	Brake+
(Reserved)	(Reserved)	Lowering output	Horn output	(Reserved)	(Reserved)	Lifting limit switch input	TX	High potential	Brake-

Controller Control Part - Functional Port Wire Number Comparison Table			
Category	Communicate with the handle	J2-1,2,3,4	31,32,33,34
Output	Lifting contactor	J1-3, J3-1	51, 24
Input	Lifting speed limited switch	J1-4, J3-1	29, 24
Input	Key switch/Charging limit switch	J1-5, J1-7	26, 26A, 27
Output	Lowering solenoid valve	J1-10, J3-1	21, 24
Output	Horn	J1-11, J3-1	25, 24
Input	Lifting height limited switch	J1-14, J3-1	30, 24
Output	Brake	J3-1, J3-2	24, 42

3.2.2 Maintenance

- ▶ The controller has no user repair accessories. Do not attempt to open, repair, or otherwise change the controller. This will damage the control and invalidate the warranty.
- ▶ It is recommended to regularly keep the controller clean and dry, and regularly check and clear diagnostic history files.
- ▶ Regular cleaning of the outside of the controller can help prevent corrosion or other electrical control failures caused by dirt, dust, and chemicals, which are part of the environment and often occur in battery powered systems.
- ▶ Before operating a battery powered vehicle, pay attention to safety. These include but are not limited to: proper training, wearing protective goggles, and avoiding loose clothing and jewelry.
- ▶ Follow the cleaning steps below to carry out the maintenance process. Never use a high-pressure flushing machine to clean the controller.
 - Remove the battery to power off.
 - By connecting a load (such as a contactor coil or horn) between controller B+ and B -, discharge the capacitor inside the controller.
 - Remove dirt or corrosion at the power and signal terminals. Wipe the controller with a damp cloth and dry it before connecting the battery.
 - The controller cannot be subjected to the impact of pressurized water flow.
 - Make sure the wiring is correct and tightened.

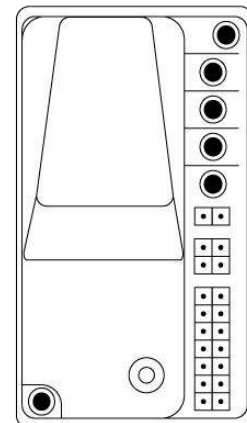



- Do not allow water to enter the product!
- Do not operate with power on!
- Do not reverse polarity!
- Do not short circuit the motor!

3.2.3 Handheld programmer

- ▶ The programmer is for easy maintenance and service of the truck.
- ▶ The programmer will automatically keep into memory after adjusting parameter, only need to key off and re-start it.



▶ **Shall not adjust controller parameter without the agreement of manufacturer, in case of truck or human accident.**

- ▶ Only these 7 controller parameters in the table below are allowed to be adjusted. Adjusting items that are not listed in the manual using a handheld unit may cause vehicle malfunctions and loss of functionality.



No	Name	Default Value	Unit	adjust range	Parameters	Remark
1	Forward percentage value	100	%	10-100	Max. forward speed	The Max. adjustment range is 100. This parameter is the Max. speed for forward travel. 100 corresponds to full speed, which corresponds to 4.5km/h on the vehicle. The larger the value, the faster the speed; the smaller the value, the slower the speed.
2	Backward percentage value	100	%	10-100	Max. backward speed	The Max. adjustment range is 100. This parameter is the Max. speed for reverse driving. 100 corresponds to full speed, which corresponds to 4.5km/h on the vehicle. The larger the value, the faster the speed; the smaller the value, the slower the speed.
3	Speed limit percentage value	40	%	10-100	Speed limit mode speed	This parameter is the driving speed in speed limit mode. The larger the value, the faster the speed; the smaller the value, the slower the speed. Percentage of Max. forward speed
4	Forward acceleration rate value	1	/	1-100	Forward acceleration rate value of walking motor	The time required for the vehicle to move forward and start at the fastest speed, the larger the value, the longer the time required, and the smaller the value, the less time required.
5	Backward acceleration rate value	1	/	1-100	Backward acceleration rate value of walking motor	The time required for the vehicle to start at the fastest speed after reversing, the larger the value, the longer the time required, and the smaller the value, the less time required.
6	Speed deceleration rate value	3	/	1-100	Deceleration rate value of walking motor	The faster the vehicle travels to stop, the longer the time required. The smaller the value, the less time required.
7	Static shutdown time	480	/	0-65535	Do not operate sleep time	After the vehicle reaches the set value without operation, the walking function is restricted and the vehicle enters a sleep state

3.2.3 Fault Code Table for handle control box



Diagnosis and Fault Guide - Fault Menu for Handheld Units:

This fault code table provides the following information:

- Fault codes(Please check the reference photo on the right)
- Fault name displayed on the programmer
- Performance caused by malfunction
- Possible causes of the malfunction



When a malfunction occurs, if it is confirmed that it is not a wiring error or a mechanical fault in the vehicle, it can be attempted to restart through the vehicle key switch. If the fault persists, please turn off the key switch, check if the connector is properly connected or dirty, repair and clean it, reconnect it, and then try again.

Fault diagnosis			
<p>When the controller software detects an error, it will stop working and warn an alarm with an LED flashing. The flashing duration will be one long and one short, indicating an error code of 11. The flashing duration will be two long and one short, indicating an error code of 21, and so on.</p> <p>The display screen will show Err XX. The displayed number corresponds to the fault code.</p>			
Fault code	Description	Possible cause	Solution
Err11	Parameter error	Parameter adjustment error or Controller failure	Copy other vehicle parameters to this controller or replace the controller.
Err12	Overcurrent	Drive motor open circuit or Controller failure	Replace the controller.
Err14	M+current 0-bit detection error	Controller failure	Replace the controller.
Err15	M-current 0-bit detection error	Controller failure	Replace the controller.
Err16	Emergency reverse switch error	When starting the machine, there is a signal from the emergency reverse switch, such as a stuck switch.	Repair the wiring or replace the emergency reverse switch
Err21	Accelerator damaged	Wiring failure or accelerator failure	Repair the wiring or replace the accelerator
Err22	Overheating current limit	Controller overheating, in current limiting operation state	Check the brakes and wiring; If normal, replace the motor. The abnormality is still present, indicating that the vehicle is overloaded. Let it cool down for about 15 minutes before using it again.
Err23	Overheat protection	Controller overheating, in shutdown state	
Err24	Motor overheat current limiting	Abnormal braking or high motor temperature, limiting current	
Err25	Motor overheat protection	Abnormal braking or high motor temperature, limiting current	
Err26	Motor stall	Motor stalling protection	Check the brakes and wiring; The abnormality is still present, replace the motor
Err27	Brake short circuit, open circuit fault	Check the brake circuit and ensure that the brakes are functioning properly.	Repair the circuit; The circuit is normal, replace the brake
	Short circuit fault of lifting horn	The lifting contactor, lowering solenoid valve, and horn circuit are short circuited.	Repair the circuit; The circuit is normal, replace the faulty component
Err29	Motor open circuit	The motor circuit is open or the motor is damaged	Repair the circuit or replace the motor
Err31	Low current limit of battery voltage	Low battery voltage, in current limiting operation state	Please charge the battery; If the battery fails, replace the battery
Err32	Low battery voltage protection	Low battery voltage, in shutdown state	Please charge the battery; If the battery fails, replace the battery
Err33	High battery voltage	Poor contact of the wiring	Repair the wiring
Err34	SRO malfunction	The handle is not pressed down, the accelerator is rotated, and the operation sequence is incorrect	Correctly use the vehicle, if the abnormality persists, replace the display screen circuit board or accelerator
Err35	Contactor error	Controller is broken	Replace the controller
Err38	Communication Error	Display screen circuit board malfunction, wiring harness malfunction	Repair the circuit or replace the display screen circuit board
Err39	Version error	Controller not flashing the correct version	Replace the controller

Attachment: List of Bolt Tightening Torques

Unit: N·m

Bolt diameter	Class			
	4.6	5.6	6.6	8.8
6	4~5	5~7	6~8	9~12
8	10~12	12~15	14~18	22~29
10	20~25	25~31	29~39	44~58
12	35~44	44~54	49~64	76~107
14	54~69	69~88	83~98	121~162
16	88~108	108~137	127~157	189~252
18	118~147	147~186	176~216	260~347
20	167~206	206~265	245~314	369~492
22	225~284	284~343	343~431	502~669
24	294~370	370~441	441~539	638~850
27	441~519	539~686	637~784	933~1244

Note: All important connections are made with grade 8.8 bolts.
The bolt grade can be found at the head, if not, it is 8.8 grade.